

The 5700B brushless motor offers extended life, high efficiency, and controllability for demanding applications. It can be provided with either a programmable integral drive control or without for connection to external trapezoidal drives. It is featured with a standard NEMA 23 mount.

## MOTOR FEATURES

**Type:** Electronically Commutated

**Voltage:** 12Vdc to 32Vdc

**Output Power:** 45 to 140 Watts with External Drive

**Phase Connection:** 3 Phase Wye

**Slot / Poles:** 12 / 8

**Rotor Magnets:** High Energy skewed to reduce cogging

**Insulation Class:** F

**Rotation:** Reversible

**Rotor Positioning:** Three Hall Effect Sensors

**Bearings:** Ball

**Mounting:** NEMA 23

## INTEGRAL CONTROL FEATURES

**Type:** Two quadrant trapezoidal programmable

**Speed Control:** 0 to 5Vdc or 0 to 10Vdc

**Protection:** Over current and over temperature

**Braking:** Dynamic

**Programming Options:** Acceleration, velocity, current limit

**Tachometer Output:** 2 Channels – 6 PPR

## OPTIONAL FEATURES

- Customized output shafts including dual output
- Various lead lengths, terminals and connectors
- Integral motor control
- Brakes: Electromagnetic
- Encoders: Incremental Optical or Capacitive

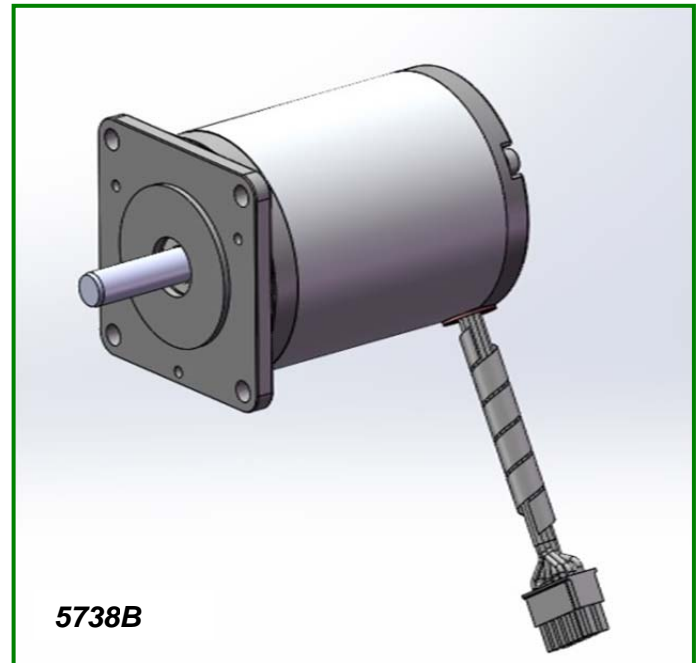

## TYPICAL APPLICATIONS

- Food Service Equipment
- Satellite positioning systems
- Pellet Stoves
- Agricultural Equipment
- Valve Actuators
- Medical / Laboratory Equipment
- Robotics
- Material Handling
- Factory and Industrial Automation
- Door and Window Automation
- Pumps

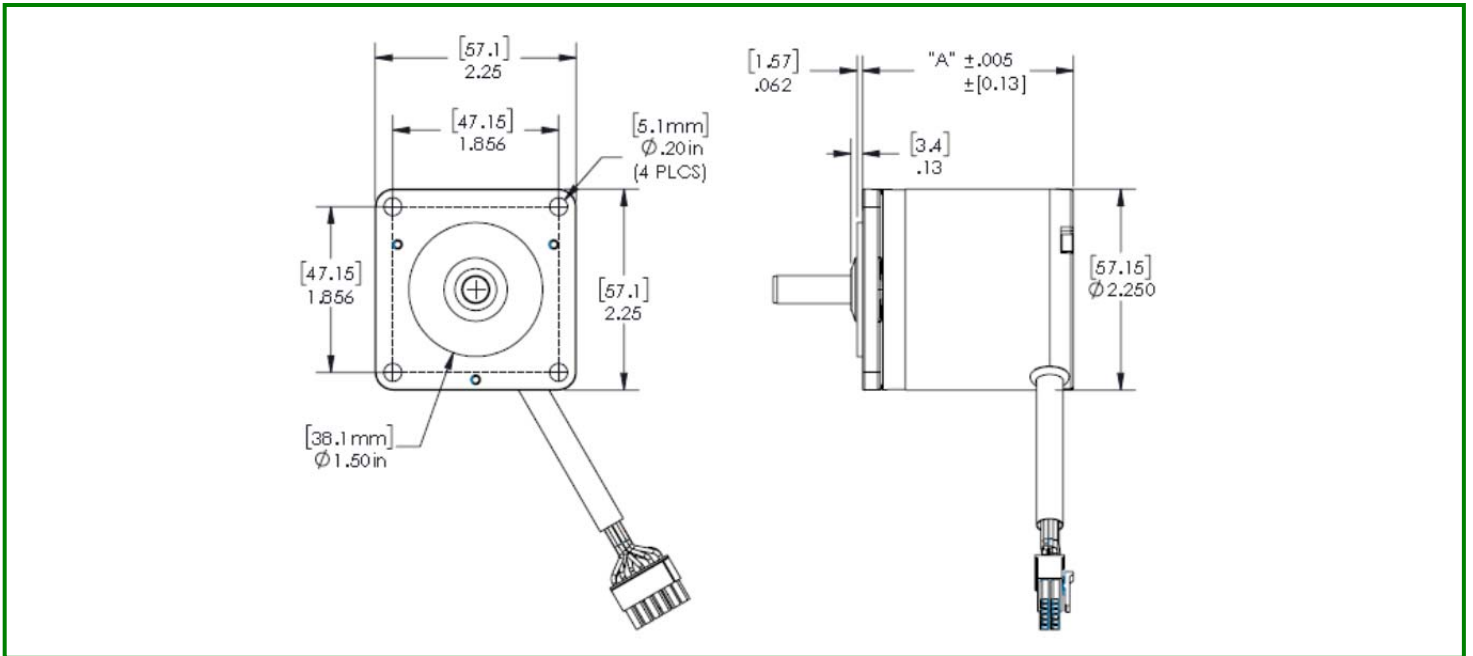

Model	Output Power (Watts) with Integral Control	Output Power (Watts) without Integral Control	Dimension "A"
5706B	12	45	1.860"[47.24]
5719B	25	100	2.360"[59.94]
5738B	45	140	3.110"[79.00]

### Integral Controller: Lead Wire Color Code

Board Position	Designation	Lead Color
1	Digital I/O "A"	Gray
2	Digital I/O "B"	White/Red
3	Direction	White/Black
4	Signal Ground	Green
5	Enable Input	Orange
6	5 Vdc (output)	Yellow
7	Input Power (12-32Vdc)	Red
8	Power Ground	Black
9	Analog Input 2	Violet
10	Analog Input 1 (speed)	Blue
11	Tachometer Output "B"	Brown
12	Tachometer Output "A"	White

### External Controller (Hall Only): Lead Wire

Board Position	Designation	Lead Color
1	Motor Phase A	Blue
2	Motor Phase B	White
3	Motor Phase C	Brown
4	Hall A	Green
5	Hall B	Orange
6	Hall C	Yellow
7	5 Vdc (Vcc)	Red
8	Ground	Black

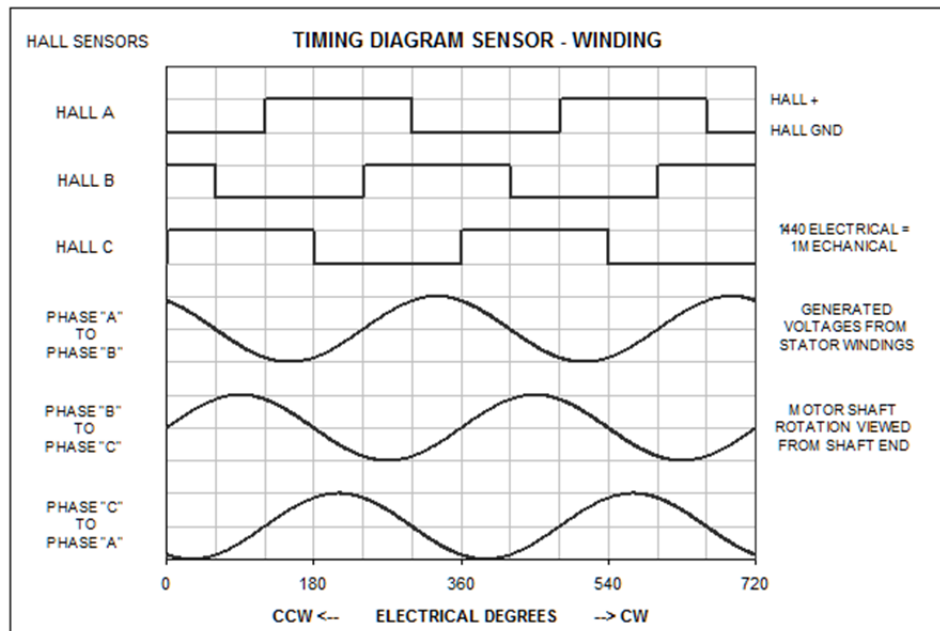

In order to properly commutate the Merkle-Korff 2.25" BLDC motor, the following table is provided to indicate the required motor phase state for a given hall-effect state.

Direction	120° Hall Spacing			Motor Phases		
	HA	HB	HC	MA	MB	MC
(NOTE 1) CW	1	0	0	DC+	OFF	DC-
	1	1	0	OFF	DC+	DC-
	0	1	0	DC-	DC+	OFF
	0	1	1	DC-	OFF	DC+
	0	0	1	OFF	DC-	DC+
	1	1	1	DC+	DC-	OFF
CW	1	0	0	DC-	OFF	DC+
	1	0	1	DC-	DC+	OFF
	0	0	1	OFF	DC+	DC-
	0	1	1	DC+	OFF	DC-
	0	1	0	DC+	DC-	OFF
	1	1	0	OFF	DC-	DC+

NOTE 1: Direction viewed from motor shaft (gearbox output shaft rotation may not be the same)