

# INSTALLATION AND OPERATING INSTRUCTIONS

## MODEL SIVF

KB Part No. 9474 – Signal Isolator for KBVF Controls

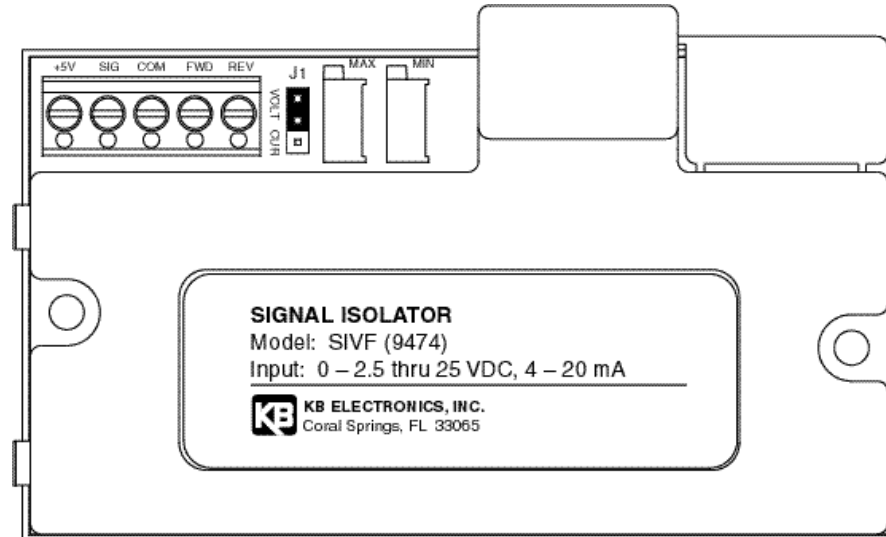

See Page 1



Pending



See Safety Warning on Page 1

The information contained in this manual is intended to be accurate. However, the manufacturer retains the right to make changes in design which may not be included herein.

**PENTA  POWER**

A COMPLETE LINE OF MOTOR DRIVES

© 1999 KB Electronics, Inc.

## TABLE OF CONTENTS

<u>SECTION</u>	<u>Page</u>
i. Safety Warning . . . . .	1
I. Introduction . . . . .	3
II. Installation Instructions . . . . .	4
III. Connections to the SIVF . . . . .	9
IV. Calibration Procedure . . . . .	13
V. Limited Warranty . . . . .	18
Addendum I . . . . .	15

### TABLE

1. General Performance Specifications . . . . .	4
2. Terminal Block Wiring Information . . . . .	9

### FIGURE

1. Control Layout . . . . .	2
2. SIVF Connection Diagram . . . . .	5
3. SIVF Mounting Diagram . . . . .	6
4A. SIVF Mechanical Specifications (Mounted to 1/2HP KBVF) . . . . .	7
4B. SIVF Mechanical Specification (Mounted to 1HP KBVF) . . . . .	8
5. Voltage Following Connection . . . . .	10
6. Current Following Connection . . . . .	11
7. Potentiometer Connection . . . . .	11
8. Unidirectional Operation . . . . .	12
9. Switch Connection . . . . .	12
10. Open Collector Connection . . . . .	13
11. Finger-Safe Cover . . . . .	16

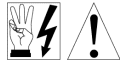

**i. SAFETY WARNING! PLEASE READ CAREFULLY**

This product should be installed and serviced by a qualified technician, electrician or electrical maintenance person familiar with its operation and the hazards involved. Proper installation, which includes wiring, mounting in proper enclosure, fusing or other overcurrent protection and grounding, can reduce the chance of electric shocks, fires or explosion in this product or products used with this product, such as electric motors, switches, coils, solenoids and/or relays. Eye protection must be worn and insulated adjustment tools must be used when working with control under power. This product is constructed of materials (plastics, metals, carbon, silicon, etc.) which may be a potential hazard. Proper shielding, grounding and filtering of this product can reduce the emission of radio frequency interference (RFI) which may adversely affect sensitive electronic equipment. If information is required on this product, contact our factory. It is the responsibility of the equipment manufacturer and individual installer to supply this safety warning to the ultimate user of this product. (SW effective 11/92)

This control contains electronic start/stop circuits that can be used to start and stop the control. However, these circuits are never to be used as safety disconnects since they are not fail-safe. Use only the AC line for this purpose.

Be sure to follow all instructions carefully. Fire and/or electrocution can result due to improper use of this product.



This product complies with all CE directives pertinent at the time of manufacture. Contact factory for detailed installation instructions and Declaration of Conformity.

**FIGURE 1 – CONTROL LAYOUT**

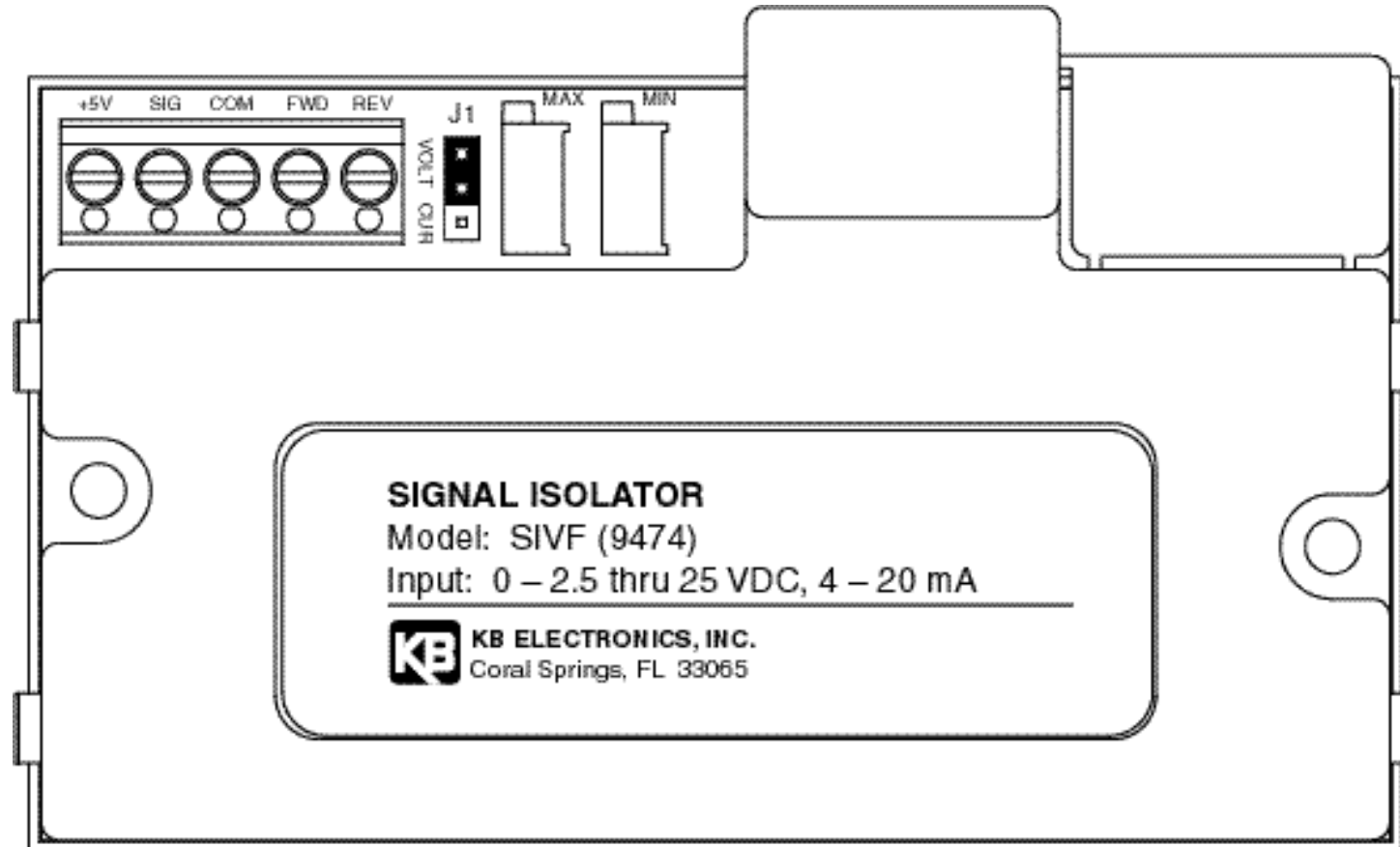

## I. INTRODUCTION

Thank you for purchasing the SIVF Signal Isolator (P/N 9474). KB Electronics, Inc. is committed to providing total customer satisfaction by producing high quality products that have been manufactured to the highest standards and techniques in the industry. The SIVF is engineered with state-of-the-art surface mount technology (SMT) incorporating advanced circuitry in a relatively small and user friendly package, making it convenient to operate and easy to install.

The SIVF is used to isolate, amplify, and condition DC voltage and current signals from any source (power supplies, motors, tachometer generators, transducers, and potentiometers). The isolated output voltage of the SIVF provides input signals to all models of the KBVF Adjustable Frequency Drive (P/N 9957, 9958, 9959, 9977, 9978, and 9979). Signal input and motor direction control is performed by making connections to the on-board barrier terminal. All inputs (+5V, SIG, COM, FWD & REV) to the SIVF are isolated from the AC line and motor connections.

The SIVF is factory calibrated to accept signal input voltage (0 – 5V DC), current (4 – 20mA DC), or a potentiometer (5K ) via a jumper selection. MIN and MAX trimpots are provided in order to readjust the SIVF. This allows the use of 0 – 2.5 thru 25V DC input voltage signals for customizing specific applications.

**TABLE 1 – GENERAL PERFORMANCE SPECIFICATIONS**

Voltage Following Operation Input Range (V DC) .....	0 – 2.5 thru 25
Current Following Operation Input Range (mA DC) .....	4 – 20
Potentiometer Operation (K ) .....	5
Output Voltage at P2 (V DC) .....	0 – 5
MIN Trimpot Range (with 0 Volts Input) (% Full Speed) .....	0 – 40
MAX Trimpot Range (with 5 Volts Input) (% Full Speed) .....	70 – 110
FWD and REV Input Switch Types .....	Dry Contact or Open Collector
Linearity (%) .....	0.5
Thermal Drift (mV/ °C) .....	1.0
Electromagnetic Compatibility (V/m at 80-1000M Hz) .....	3

**II. INSTALLATION INSTRUCTIONS**

Note: If the KBVF contains a finger safe cover, (KB P/N 9473) see Addendum I on page 15.

**See figure 2, SIVF Connection Diagram, on page 5.**



**WARNING: HIGH VOLTAGE IS PRESENT WHILE LEDs ARE ILLUMINATED.**

Before wiring the SIVF to the KBVF, disconnect all power to the KBVF and wait until “PWR” and “ST” LEDs are no longer illuminated.

**A. Wiring the SIVF to the KBVF –** (Note: Do not install the SIVF to the KBVF until wiring is completed.)

1. Remove the F-S-R jumper which is installed on CONN2 of the KBVF. Attach the 3-pin connector (with white, black, and red wires) from the SIVF to the KBVF connector marked “CONN2”.
2. Attach the red wire from the SIVF to the KBVF terminal marked “J3”.
3. Attach the orange wire from the SIVF to the KBVF terminal marked “P2”.

**FIGURE 2 – SIVF CONNECTION DIAGRAM**

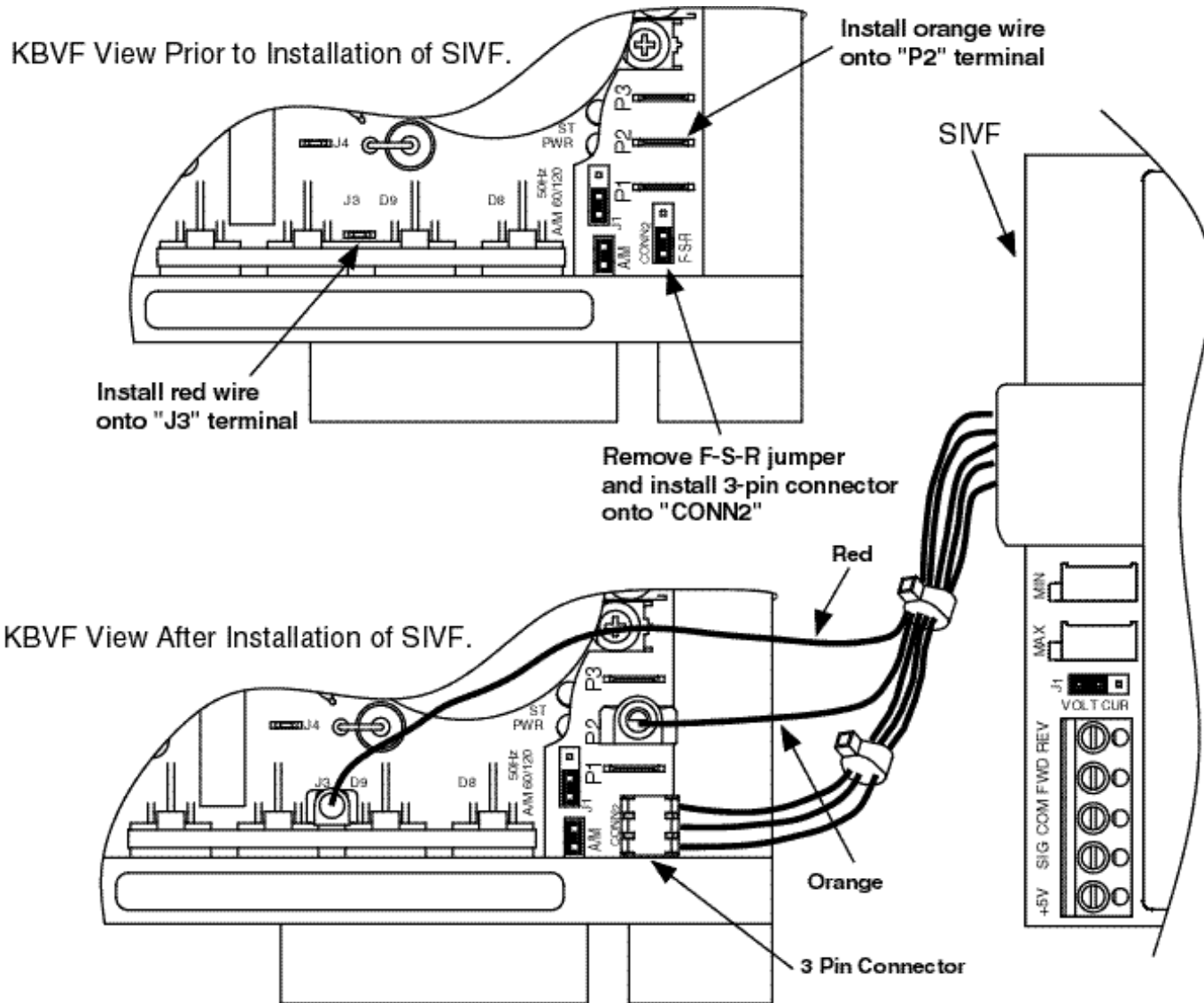

### FIGURE 3 – SIVF MOUNTING DIAGRAM

(Shown Mounted to Model KBVF-24D)

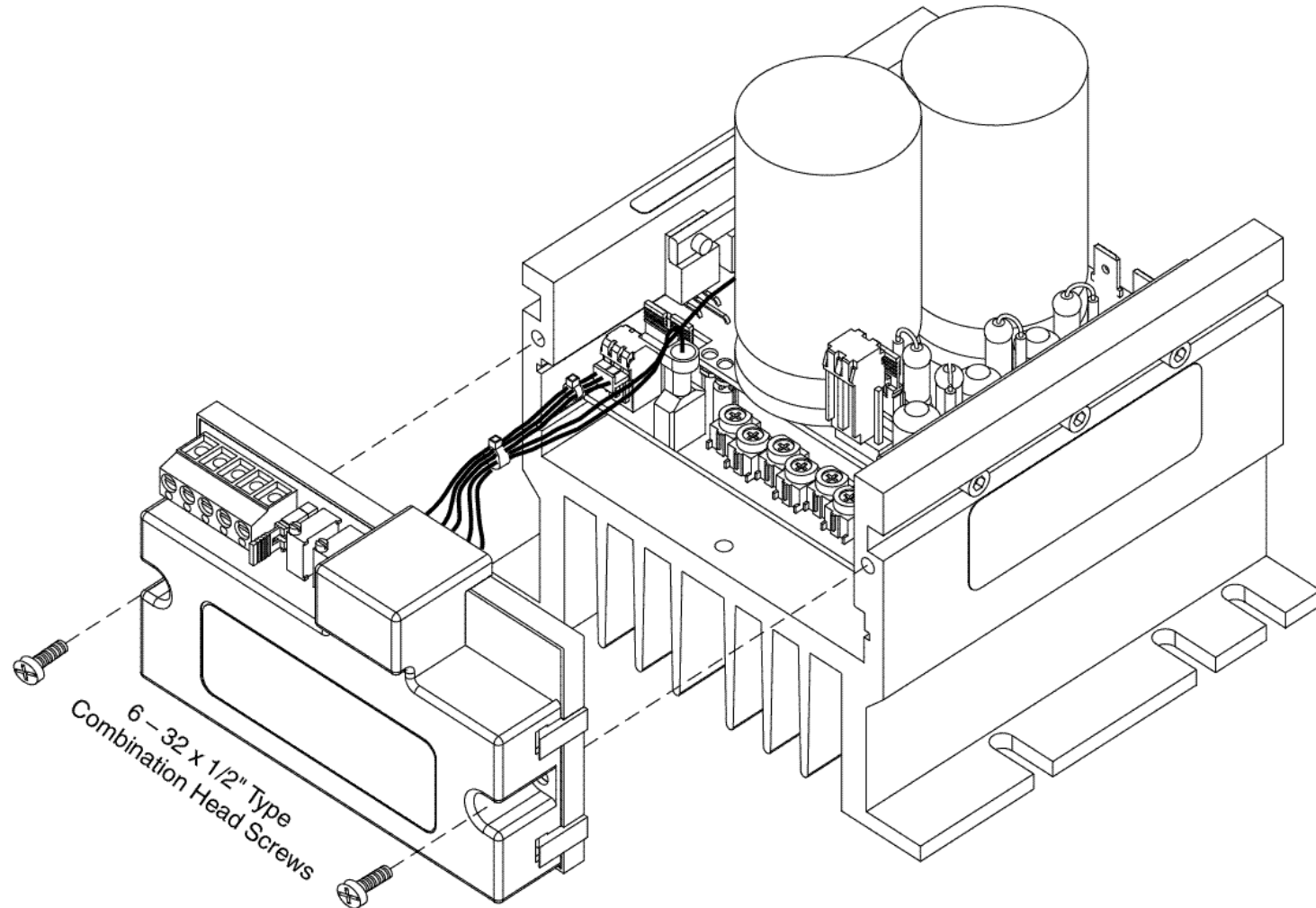



# FIGURE 4A – SIVF MECHANICAL SPECIFICATIONS (Inches / mm)

(Shown Mounted to 1/2HP KBVF – With Optional Finger-Safe Cover)

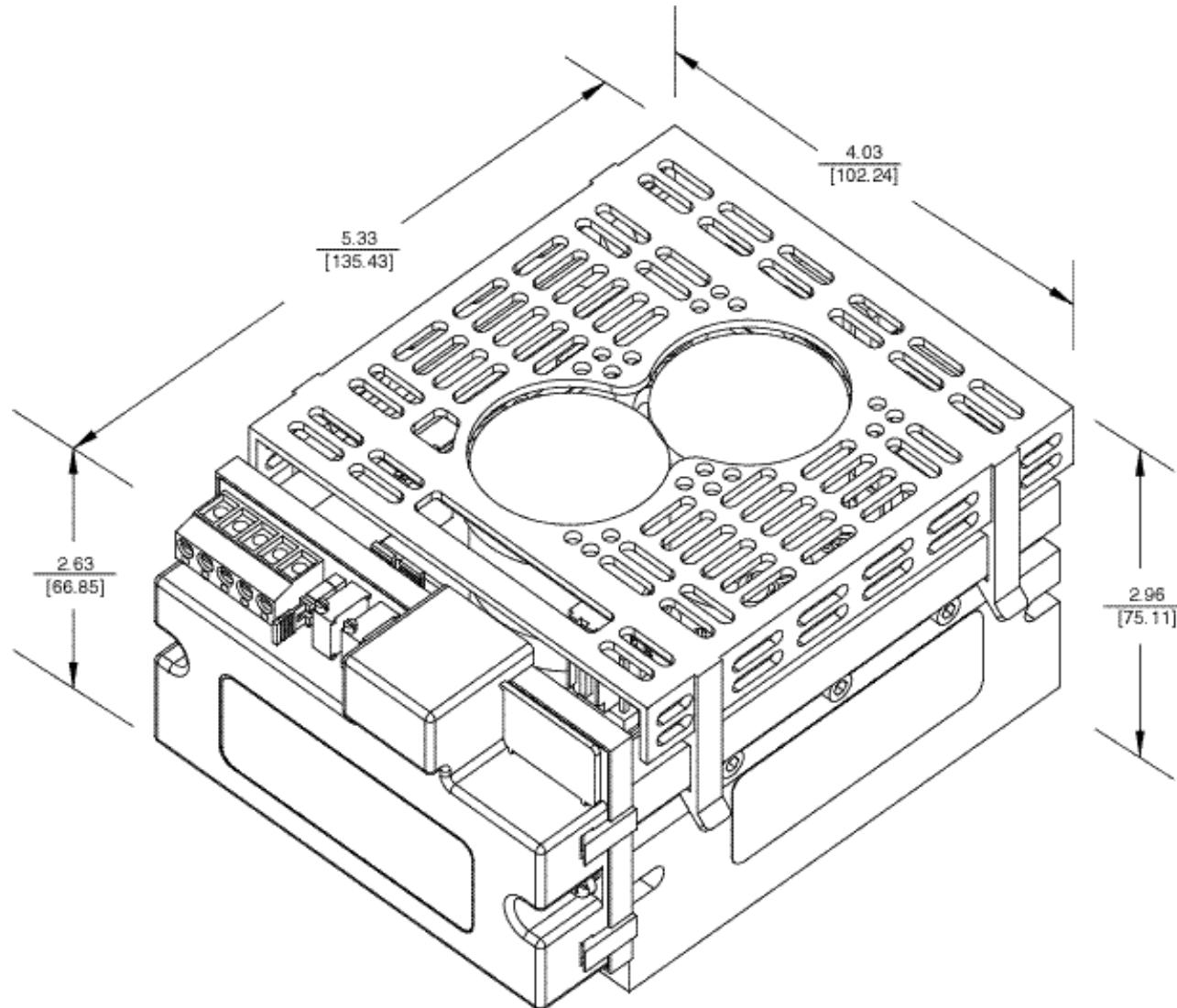

**FIGURE 4B – SIVF MECHANICAL SPECIFICATIONS (inches / mm)**  
(Shown Mounted to 1HP Model KBVF)

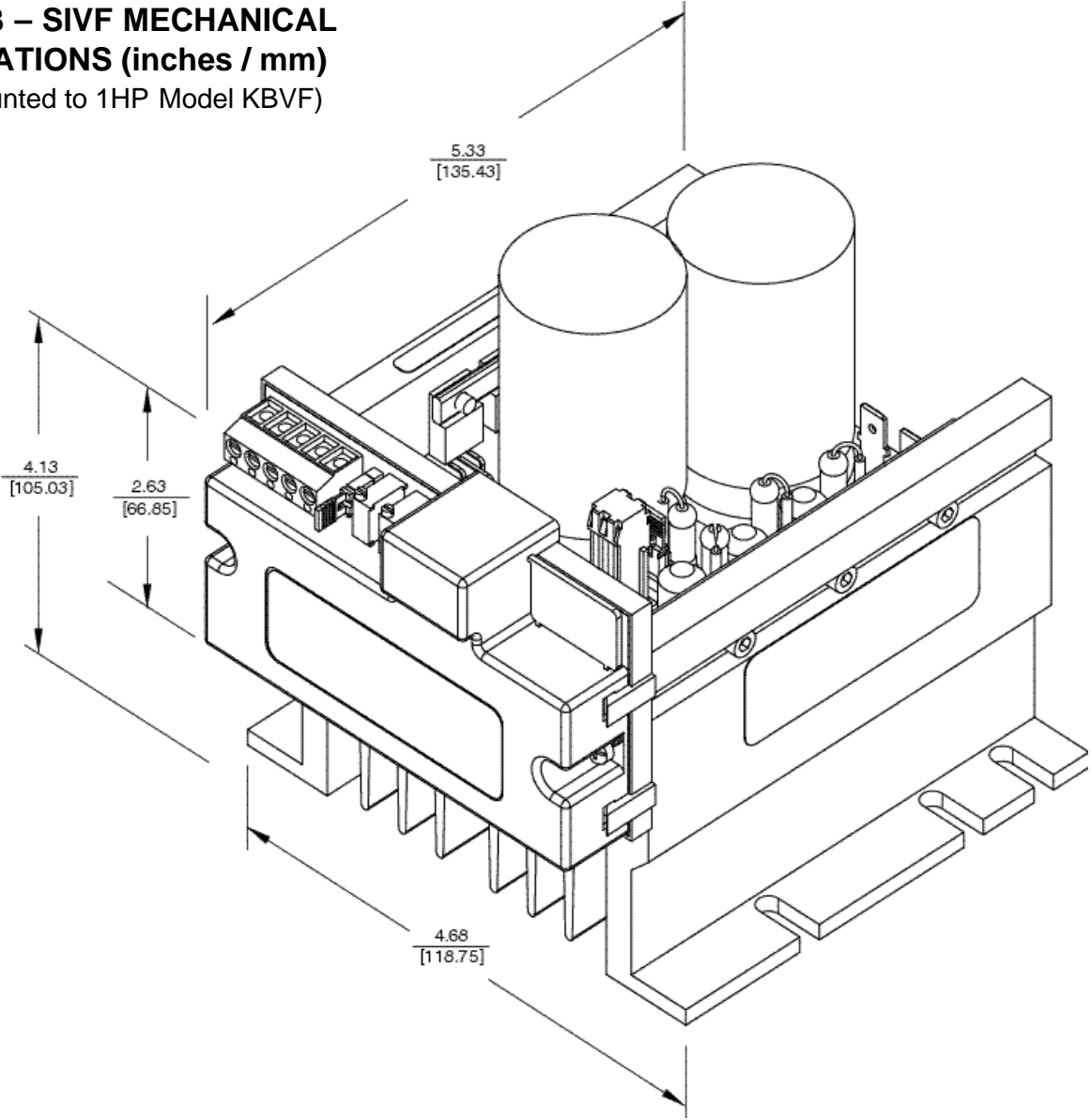

## B. MOUNTING THE SIVF ONTO THE KBVF

See figure 3, SIVF Mounting Diagram.

See figures 4A and 4B, SIVF Mechanical Specifications, on pages 7 and 8.

The SIVF is installed onto the KBVF using (2) two 6-32 X 1/2" screws provided.

Note: The screws are a combination head type which allow the use of a readily available #1 or #2 phillips or slotted head screwdriver.

Note: Before installing the SIVF be sure the wiring to the KBVF has been completed. See section II, Installation Instructions, on page 3

1. Align the SIVF mounting holes with the tapped holes on the KBVF heat sink and insert the screws through the SIVF mounting holes.
2. Using a screwdriver, fasten both screws until the SIVF is secured to the KBVF (8 in-lbs max). Do not over tighten screws or damage may result to SIVF cover.

**TABLE 2 – TERMINAL BLOCK WIRING INFORMATION**

Connection Designation	Supply Wire Gauge (AWG – Cu)		Maximum Tightening Torque (in-lbs)
	Minimum	Maximum	
Logic Connections	24	14	3.5

## III. CONNECTIONS TO THE SIVF



**Safety Warning!** Do not use FWD-STOP-REV contacts as a safety disconnect since they are not fail-safe. Use only the AC line for this purpose.

**Note: A connection must be made between FWD and COM or REV and COM in order for control to operate. Jumper shown installed in FWD direction.**

See Table 2, Terminal Block Wiring Information, on page 9.

Note: The MIN and MAX trimpots on the KBVF are non-operational after the SIVF is installed.

### A. Signal Following

In this mode, a signal source is used to vary motor speed.

- i. **Voltage Following** – Uses a voltage source to vary motor speed.

Set J1 to “VOLT” position and connect the voltage source to TB1 terminals SIG (+) figure 5, Voltage Following Connection. Be :  
 tive (+) signal is connected to “SIG” terminal  
 negative (-) is connected to the “COM” termi  
 nal.

When a 0V DC signal is applied, the motor will operate at the minimum set speed (set by the MIN trimpot on the SIVF). When a 5V DC signal is applied, the motor will operate at the maximum set speed (set by the MAX trimpot on the SIVF).

Figure 5 – Voltage Following Connection (Jumper J1 in “VOLT” Position)

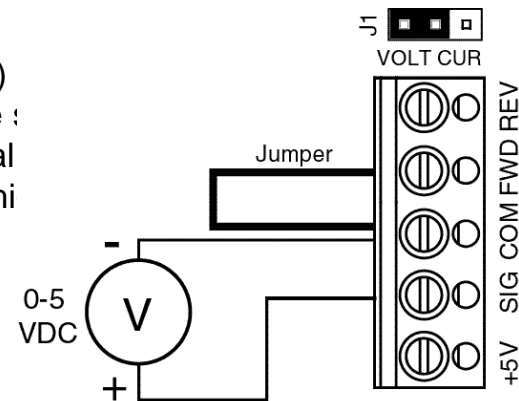

- ii. **Current Following** – Uses a current source to vary motor speed.

Set J1 to “CUR” position and connect the current source to TB1 terminals SIG (+) and COM (-). See figure 7, Current Following Connection, on page 11.

Be sure the positive (+) signal is connected to “SIG” terminal and the negative (-) is connected to the “COM” terminal.

When a 4mA DC signal is applied, the motor will operate at the minimum set speed (set by the MIN trimpot on the SIVF). When a 20mA DC signal is applied, the motor will operate at the maximum set speed (set by the MAX trimpot on the SIVF)

**B. Potentiometer Operation** – Uses a potentiometer to vary motor speed.

Set J1 to “VOLT” position and connect the 5K potentiometer to TB1 terminals marked “SIG” (wiper of potentiometer), “+5” (high side of potentiometer), and “COM” (low side of potentiometer). See figure 7 Potentiometer Connection. When the potentiometer is set to 0% (counter-clockwise position), the motor will operate at the minimum set speed (set by the MIN trimpot on the SIVF). When the potentiometer is set to 100% (full clockwise position) the motor will operate at full speed (set by the MAX trimpot on the SIVF)

**C. Unidirectional Operation**

To operate the control in forward, install a jumper between “FWD” and “COM” terminals of the SIVF

To operate the control in reverse, install a jumper between “REV” and “COM” terminals

Figure 6 – Current Following Connection (Jumper J1 in “CUR” Position)

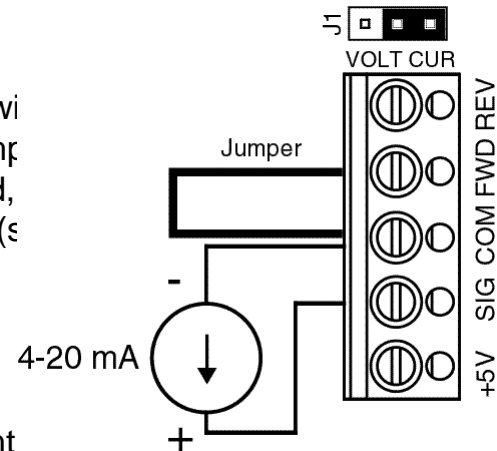
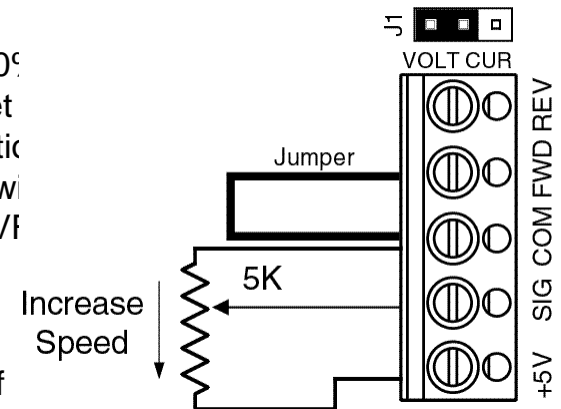

Figure 7 – Potentiometer Connection (Jumper J1 in “VOLT” Position)



nals of the SIVF. See figure 8, Unidirectional Operation.

Note: A SPDT switch or contact can be used as an enable to turn control on and off electronically.

Figure 8 – Unidirectional Operation

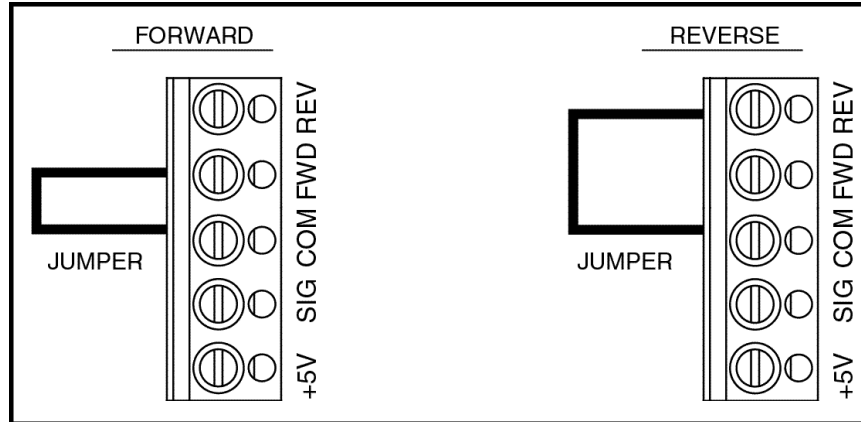

**! Safety Warning!** Do not use FWD-STOP-REV contacts as a safety disconnect since they are not fail-safe. Use only the AC line for this purpose.

**D. Bidirectional Operation**

- i. **Switch Connection –**  
Connect the normally open single pole double throw (SPDT) maintained switch with center off position as shown in figure 9. The center, or common terminal of the switch connects to the “COM” terminal of the SIVF and the normally open terminals of the switch connect to the “FWD” and “REV” terminals of the SIVF.

Figure 9 – Switch Connection (Forward-Stop-Reverse)

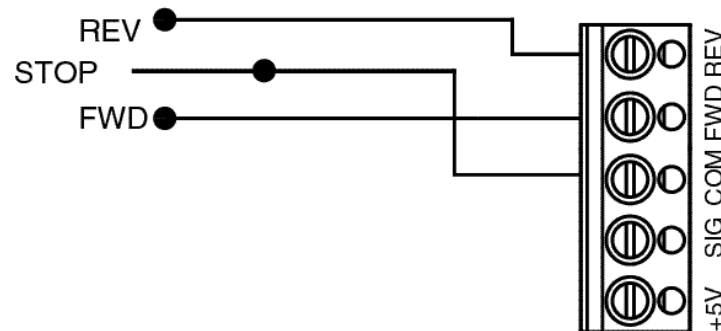

Making the connection between “COM” and “FWD” terminals will operate the motor in the forward direction. Making the connection between the “COM” and “REV” terminals will operate the motor in the reverse direction. If no connections are made to either FWD or REV terminals, the motor will be in the STOP state. See figure 9, Switch Connections, on page 12. If the motor runs in the opposite intended direction, interchange FWD and REV connections.

Figure 10 – Open Collector Connection (Forward-Stop-Reverse)

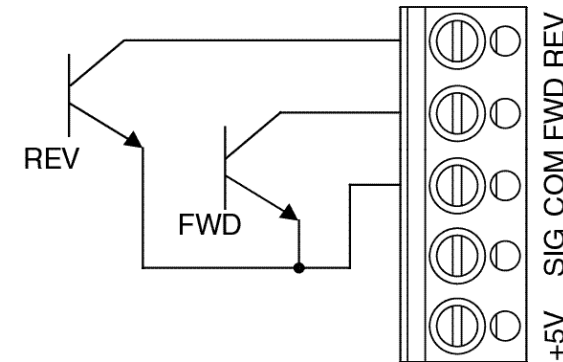

 **Warning:** Be sure to disconnect AC power, and wait until “PWR” and “ST” LEDs are no longer illuminated. HIGH VOLTAGE IS PRESENT WHILE LEDs ARE ILLUMINATED.

- ii. **Open Collector Transistor Connections** – Connect the open collector transistor circuit as shown in figure 10. Both emitters of the transistor circuit connect to the “COM” terminal of the SIVF and the collectors of the transistor circuit connect to the “FWD” and “REV” terminals of the SIVF.

#### IV. CALIBRATION PROCEDURE (See Safety Warning on Page 1)

The SIVF is factory calibrated, but readjustments to the MIN and MAX trimpots can be made to customize for a particular signal input requirement.

Note: Adjustments to the MAX trimpot will affect the MIN trimpot setting. It may be necessary to repeat steps 1 through 5 to achieve accurate calibration settings. For best results, adjust MAX trimpot before adjusting MIN trimpot.

- A. Calibrating the SIVF for Voltage Following (Jumper J1 in “VOLT” position):**
1. Select FWD or REV direction.
  2. Apply the maximum voltage input signal.
  3. Monitor KBVF output and adjust the MAX trimpot on SIVF for the desired maximum setting.
  4. Apply the minimum voltage input signal.
  5. Monitor KBVF output and adjust the MIN trimpot on SIVF for the desired setting.
- B. Calibrating the SIVF for Current Following (Jumper J1 in “CUR” position):**
1. Select FWD or REV direction.
  2. Apply the maximum current input signal.
  3. Monitor KBVF output and adjust the MAX trimpot on SIVF for the desired maximum setting.
  4. Apply the minimum current input signal.
  5. Monitor KBVF output and adjust the MIN trimpot on SIVF for the desired minimum setting.
- C. Calibrating the SIVF for Potentiometer Operation (J1 in “VOLT” position):**
1. Select FWD or REV direction.
  2. Set potentiometer to 100% (fully clockwise).
  3. Monitor KBVF output and adjust the MAX trimpot on SIVF for the desired KBVF output.
  4. Set potentiometer to 0% (fully counterclockwise).
  5. Monitor KBVF output and adjust the MIN trimpot on SIVF for the desired minimum setting.



## – ADDENDUM I –

### Instructions to Modify the Optional Finger-Safe Cover (KB P/N 9473).

If using the optional finger-safe cover on the KBVF, it needs to be modified to install the KBVF.



**WARNING:** HIGH VOLTAGE IS PRESENT WHILE LEDs ARE ILLUMINATED.

Before removing the finger safe cover, or wiring the KBVF, disconnect all power to the KBVF and wait until “PWR” and “ST” LEDs are no longer illuminated.

Note: If a finger-safe cover is already installed on the KBVF, remove it by lifting up on the four (4) retaining clips (see figure 11, Finger-Safe Cover, on page 16).

#### Instructions to modify the finger-safe cover:

1. Cut off the end section with three (3) tabs of the finger-safe cover at nine (9) places, as shown in figure 11, Finger-Safe Cover.
2. Before installing the finger-safe cover onto the KBVF, connect orange wire, red wire and 3-pin connector to KBVF.
3. Install SIVF onto KBVF before installing the finger-safe cover (see section II, on page 4).
4. Install the finger safe cover onto the KBVF using the four (4) retaining clips.

**FIGURE 11 – FINGER-SAFE COVER**

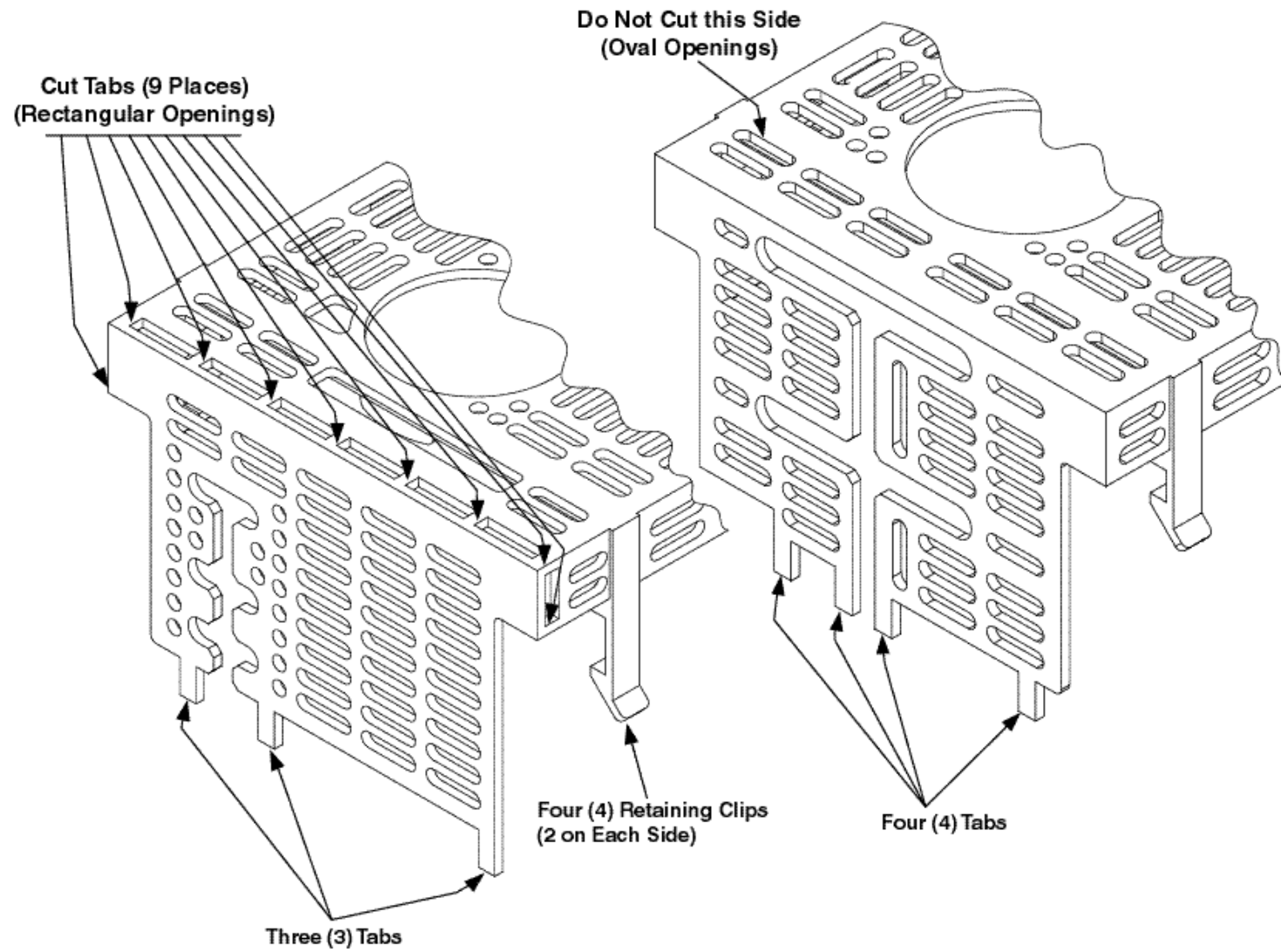

– NOTES –

## V. LIMITED WARRANTY

For a period of 18 months from date of original purchase, KB will repair or replace without charge devices which our examination proves to be defective in material or workmanship. This warranty is valid if the unit has not been tampered with by unauthorized persons, misused, abused, or improperly installed and has been used in accordance with the instructions and/or ratings supplied. The foregoing is in lieu of any other warranty or guarantee, expressed or implied, and we are not responsible for any expense, including installation and removal, inconvenience, or consequential damage, including injury to any person, caused by items of our manufacture or sale. Some states do not allow certain exclusions or limitations found in this warranty so that they may not apply to you. In any event, KB's total liability, under all circumstances, shall not exceed the full purchase price of this unit. (rev 4/88)



### **KB ELECTRONICS, INC.**

12095 NW 39th Street, Coral Springs, FL 33065-2516 • (954) 346-4900 • Fax (954) 346-3377  
Outside Florida Call **TOLL FREE** (800) 221-6570 • E-mail – [info@kbelectronics.com](mailto:info@kbelectronics.com)  
[www.kbelectronics.com](http://www.kbelectronics.com)