



**Elevator**

**IMPERIAL 543 | 545 MACHINE SURVEY**

PROJECT INFORMATION			
JOB NAME		SHIP DATE	
CUSTOMER		NO. OF CARS	
CONTACT PERSON		JOB TYPE	

**MACHINE INFORMATION**  
We require all items to be filled out and provided to ensure accuracy.

**IMPERIAL GEARLESS MACHINE:**

CAR LABELS		BUILDING POWER SUPPLY	
CAPACITY (LBS)		EXISTING MACHINES MAKE-MODEL	
SPEED (FPM)			
CAR WEIGHT (LBS)			
COUNTERWEIGHT (%)	50%	CONTROLLER MANUFACTURER	
ROPING	<input type="checkbox"/> 2:1 <input type="checkbox"/> 4:1	DRIVE MANUFACTURER	
ROPE DIAMETER		ENCODER CABLE LENGTH	
ROPE QUANTITY		ASME A17 CODE COMPLIANCE	<input type="checkbox"/> 2013 <input type="checkbox"/> 2016 <input type="checkbox"/> 2019 <input type="checkbox"/> 2022
ROPE DROP (M)	543 Machine - 480mm 545 Machine - 600mm	SEISMIC ZONE	<input type="checkbox"/> NO <input type="checkbox"/> ZONE 3 <input type="checkbox"/> ZONE 4
TRAVEL (FT)		ROPE GRIPPER	<input type="checkbox"/> YES <input type="checkbox"/> NO

**SKETCH A**

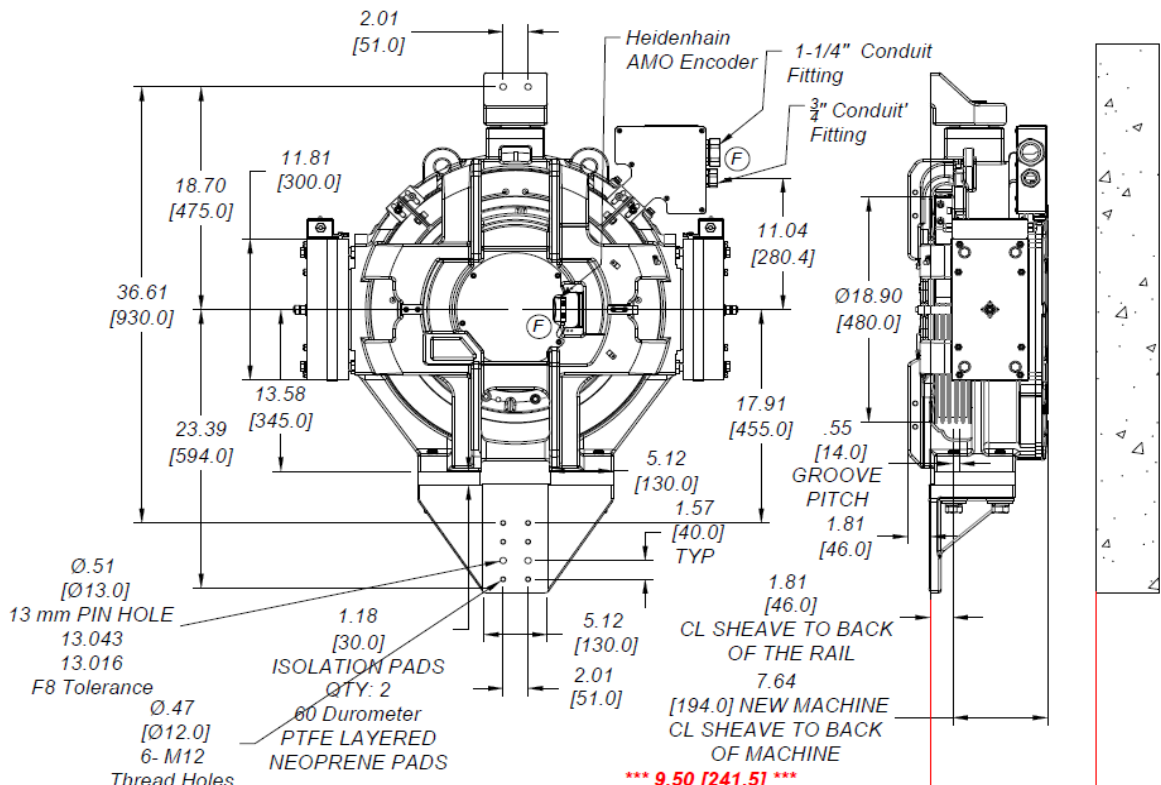

**\*\*\* 9.50 [241.5] \*\*\***  
**CRITICAL MIN DIMENSION**  
**REQUIRED TO FIT NEW MACHINE**  
**\*\*FROM BACK OF THE RAIL TO WALL\*\***

**FRAME 543 MODEL SHOWN SKETCH A**

**EXISTING DIMENSION=**

SKETCH B

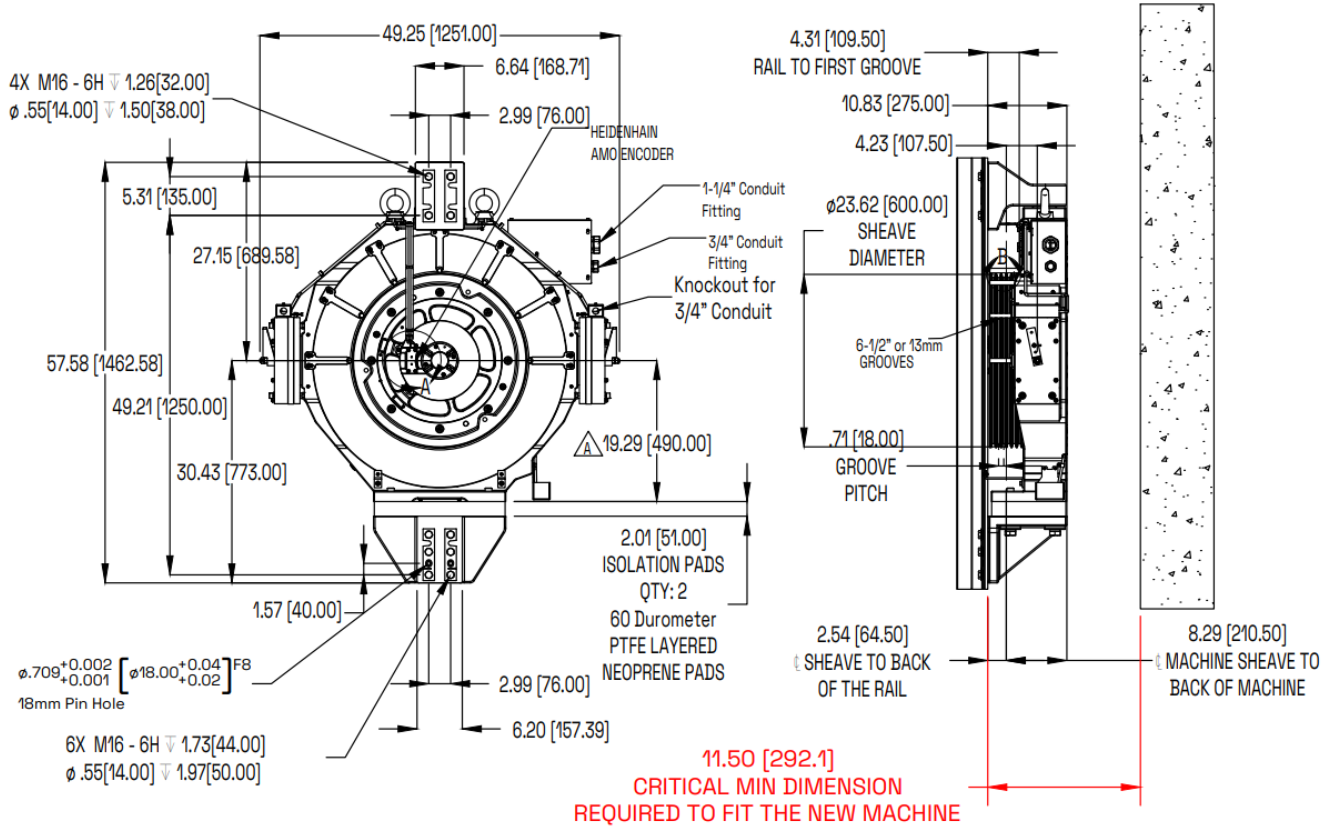

FRAME 545 MODEL SHOWN SKETCH B

Notes:

1. Ensure that all fields are properly completed and filled out.
2. Provide machine room plan sketch and/or existing machine pictures if available.
3. You may contact **Imperial Engineering** using: Office **330-734-3600** –| Dial **"3"** for Engineering

REMARKS:



Imperial Electric

2575 Greensburg Rd, North Canton, OH 44720 | [www.nidecelevatorgroup.com](http://www.nidecelevatorgroup.com)  
 Office 330-734-3600 – Dial "1" for Imperial Electric Elevator | Dial "3" for Engineering