

FRAME Low Speed (LS) Series: 478-LS, 522-LS, 525-LS, 527-LS

Single Wrap

Frame LS Series has the capacity to lift 1,000 to 4,500 lbs. at traditional geared speeds from 100 to 450 fpm with 1:1 roping.

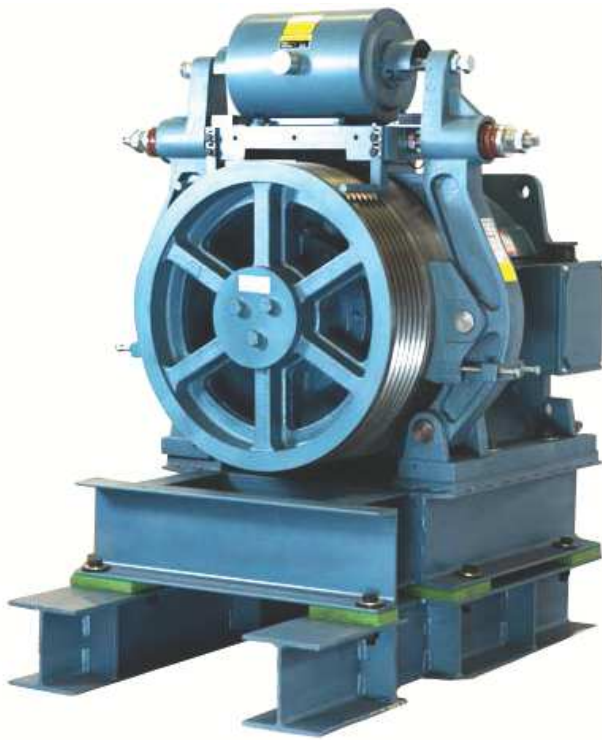

MODEL 478-LS

- 1,750 lbs. package weight
- 12,000 lbs. maximum sheave shaft load
- 20 inch sheave
- 5-1/2 inch V grooves single wrap
- 1,111 ft.-lbs. brake torque per shoe
- UL/CSA CUS Certified

MODEL 522-LS

- 2,875 lbs. package weight
- 17,600 lbs. maximum sheave shaft load
- 20 inch sheave
- 7-1/2 inch V grooves single wrap
- 1,868 ft. lbs. brake torque per shoe
- UL/CSA CUS Certified

MODEL 525-LS/527-LS

- 3,830 lbs. (525-LS)/3,980 lbs. (527-LS) package weight
- 22,000 lbs. maximum sheave shaft load
- 25 inch sheave
- 527-LS requires rope brake over 4,000 lb. capacity
- 7-1/2 inch or 6-5/8 inch V grooves single wrap
- 3,190 ft.-lbs. brake torque per shoe
- UL/CSA CUS Certified

LS PACKAGE INCLUDES:

- Motor
- Dual Coil Brake - Independent brake system holds 125% rated capacity
- Drive Sheave
- Endat Encoder
- Single Tier Base
- Blocking beams
- Dynamic Isolation
- Hardware for bolting the machine to the blocking
- Sheave guard
- Rope retainer

FRAME LS Series 1:1 duty table

FPM	100		200		300		400		450	
	HP	AMPS	HP	AMPS	HP	AMPS	HP	AMPS	HP	AMPS
1000	1.7	12.2	3.4	12.2	5.9	12.2	6.7	12.2	17.8	22.0
1500	2.5	18.3	5.1	18.3	8.8	18.3	10.1	18.3	17.0	17.0
1800	3.0	20.0	6.1	20.0	10.6	20.0	12.1	20.0	22.3	20.0
2200	3.7	22.0	7.4	22.0	13.0	22.0	14.8	22.0	24.5	22.0
2500	4.2	25.0	8.4	25.0	14.7	25.0	16.8	25.0	18.9	25.0
3000	5.1	30.0	10.1	30.0	17.7	30.0	20.2	30.0	22.7	30.0
3500	5.9	35.0	11.8	35.0	20.6	35.0	23.6	35.0	26.5	35.0
4000	6.7	43.0	13.5	43.0	20.2	43.0	26.9	43.0	30.3	43.0
4500	7.6	48.0	15.2	48.0	22.7	48.0	30.3	48.0	34.1	48.0
Model 478-LS			Model 522-LS		Model 525-LS		Model 527-LS			

50% counterweight. Consult Imperial Electric for 40% and 45% counterweighting data.

Gearless AC Machines

Frame 500 series dimensional diagrams

Model 522

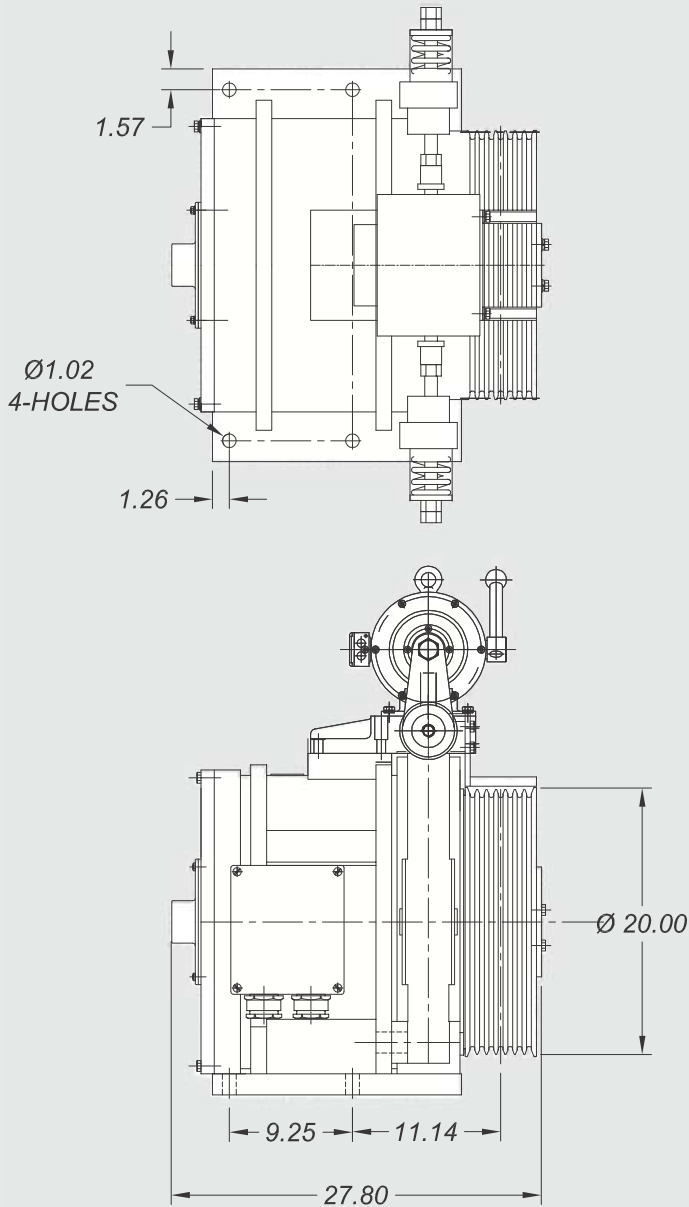

Model 522/522LS

NOTE:

FRAME: 522/522LS

DRIVE SHEAVE: 20" WITH

(7) - $\frac{1}{2}$ " V GROOVES

MOTOR WEIGHT: 2469 LBS

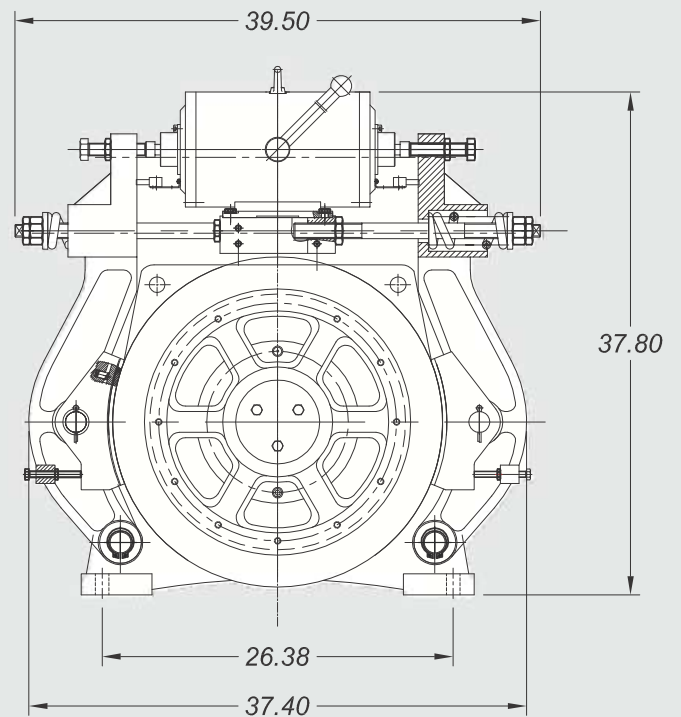

Gearless AC Machines

Frame 500 series dimensional diagrams

Model 522 with base

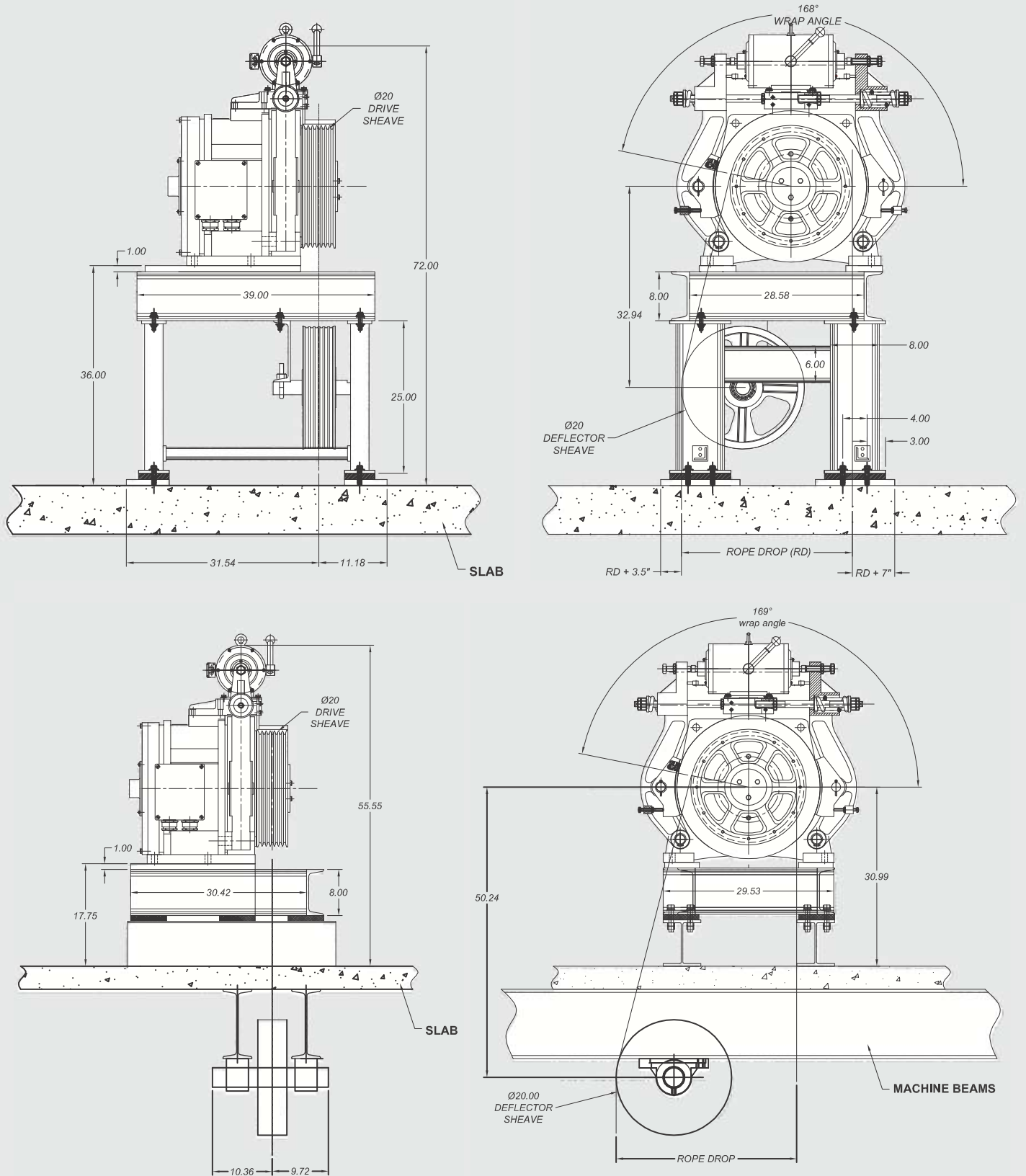

Note: Contact Imperial Electric for actual dimensions.