

CUSTOMER NAME: _____

JOB NAME: _____

- GEARLESS AC MACHINE QUANTITY: _____
- CAR CAPACITY: _____
- CAR SPEED: _____
- ROPING: _____
- TRAVEL HEIGHT _____
- EMPTY CAR WEIGHT _____
- CWT %: _____
- HOIST ROPES:
QUANTITY: _____ SIZE: _____
- PITCH OF HOIST ROPES: _____
- COMPENSATION: TYPE ROPE CHAIN
COMPENSATION ASSUMED TO BE 100%
- "ROPE DROP" SEE SKETCH "C"-DIM "R" _____
- BUILDING POWER SUPPLY (VOLT.): _____

- MODEL: _____
- CONTROLLER MANUFACTURER: _____
- RETAINING AN EXISTING DEFLECTOR SHEAVE?
IF YES: DIAMETER _____
IF NO: REQUIRED DIAMETER SHEAVE TRACTION _____
- ENCODER CABLE LENGTH:
 (35 FT MAGNETEK) (45 FT KEB)
- ASME A17 CODE COMPLIANCE TO WHICH REVISION _____
- SEISMIC ZONE: IF YES: ZONE 3 ZONE 4
IF NO:
- DRIVE MANUFACTURER _____ OTIS _____ SCHINDLER
_____ KEB _____ MAGNETEK _____ TKE 10K

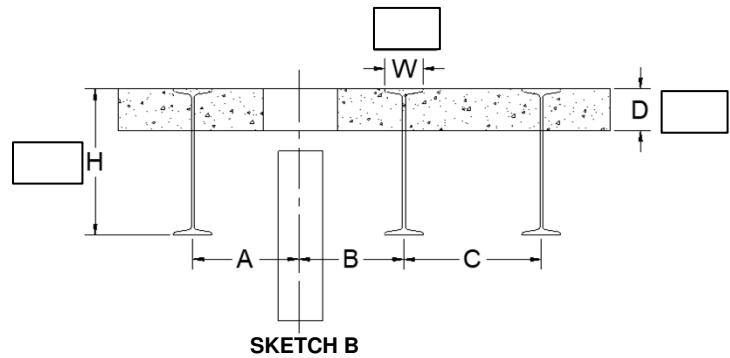
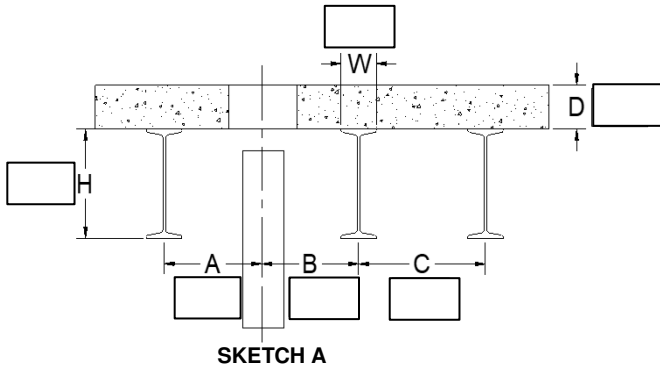

MACHINE BEAMS LOCATION

- BEAM SPACING (SEE SKETCH "A"- DIM. "A", "B", & "C")
- BEAM / CHANNEL SIZE: _____ H x _____ "W"
- FLOOR SLAB THICKNESS: _____ (DIM. "D")
- IF SECONDARY MOUNTING IN MACHINE ROOM
 YES [FINISH ON PAGE 2]

BREAKDOWN CRATING REQUIRED: NO YES
(Machine is separated into major components to reduce size and weight for easier handling).

- OPTION 1: BRAKE SHIPPED SEPARATELY
- OPTION 2: FRAME, ROTOR SHEAVE ASSEMBLY AND BRAKE PARTS SHIPPED SEPARATELY (requires extensive customer technical expertise to re-assemble correctly and safely).
- IMPERIAL TO PROVIDE ON-SITE TECHNICIAN TO RE-ASSEMBLE MACHINE

ADDITIONAL CHARGES APPLY TO ALL OPTIONS.

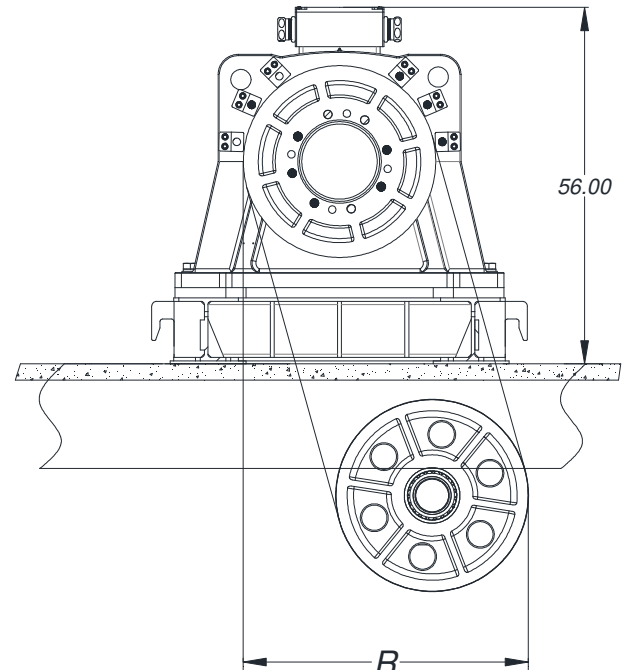

FRAME 9080B MODEL SHOWN WITH LS PACKAGE IN SKETCH C

IMPERIAL GEARLESS SURVEY (JOB SITE INFORMATION)

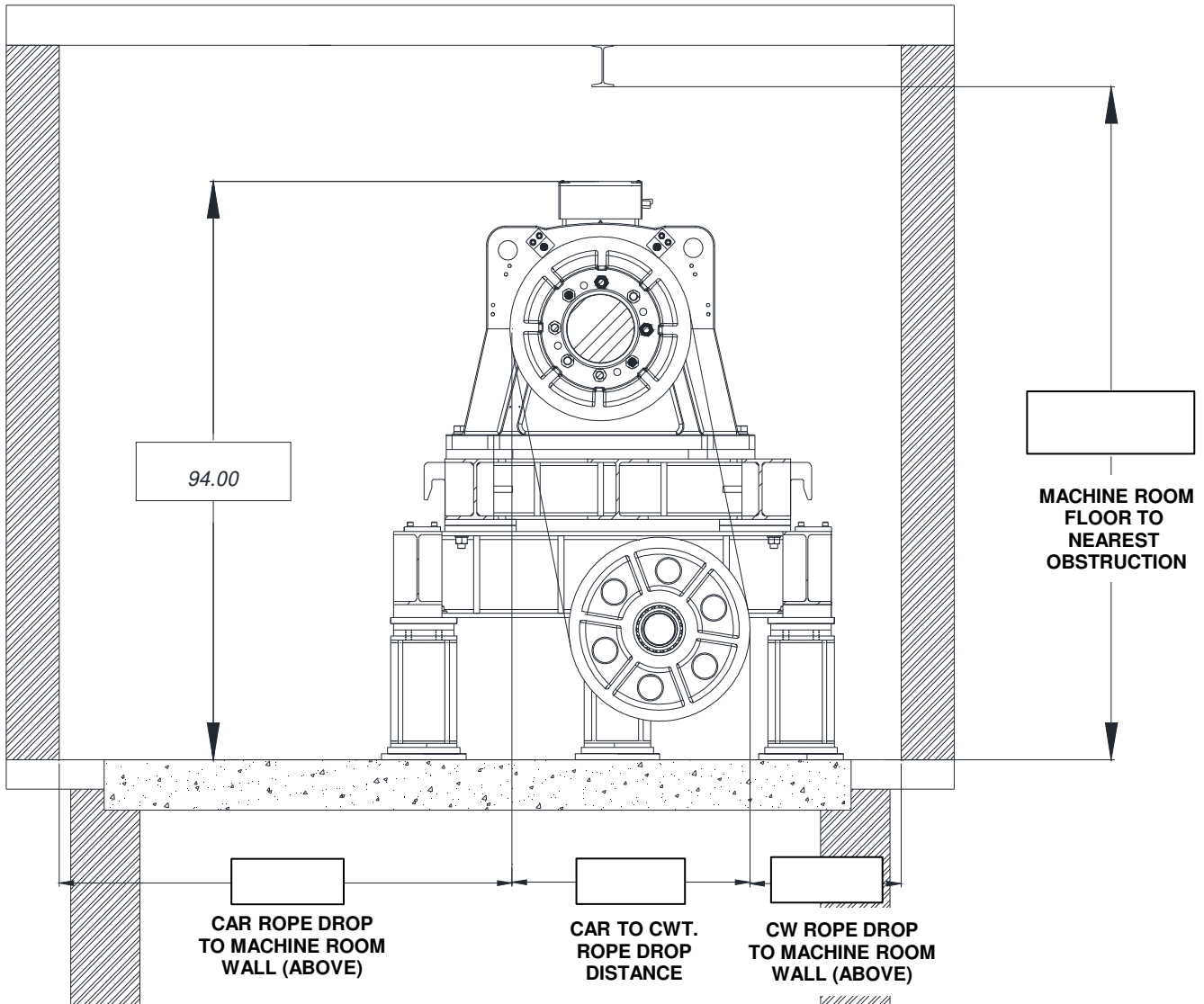

**SKETCH D
VIEW FACING THE MACHINE SHEAVE
RIGHT-HAND SWING SHOWN**

NOTES:

1. FILL IN DIMENSIONS
2. PROVIDE MACHINE ROOM PLAN SKETCH (IF AVAILABLE).
3. INDICATE LEFT-HAND SWING OR RIGHT-HAND SWING MACHINE REQUIRED:

Select one

NOTE: SKETCH D SHOWS RIGHT-HAND SWING

FRAME 9080B MODEL SHOWN WITH TABLE TOP PACKAGE IN SKETCH D