

Instruction Manual

Installation
Operation
Maintenance

Cross Current Analyzer
DDG-51 and AOE-6 Redundant
Voltage Regulator System
509-00150-10

Publication
351-09002-00 (December 1991)



Safety Summary

Observe the safety precautions that follow and the instructions contained in this manual when installing, operating, testing and making repairs to this equipment.

WARNING

De-energize generator set starting circuit before making repairs, connecting test instruments or removing or making connections to or within the voltage regulator. Dangerous voltages are present at the voltage regulator terminal board and within the voltage regulator when the generator set is running. These include the sensing voltage, power to the voltage regulator and the voltage regulator output. Accidental contact with live conductors could result in serious electrical shock or electrocution.

CAUTION

Megger or high potential test equipment must not be used when testing the voltage regulator. Disconnect interconnecting conductors between the generator and voltage regulator when testing generator or exciter with megger or high potential test equipment. The high voltage developed by megger or high potential test equipment will destroy the solid state components within the voltage regulator.

TABLE OF CONTENTS

CHAPTER	CONTENT	PAGE
	Cover	1
	Safety Summary	2
	Table of Contents	3
1	Introduction	4
2	General And Functional Description	5
2.0	General	5
2.1	Section One - Cross Current	5
2.2	Section Two - Current Limiter	6
3	Adjustment of Redundant Voltage Regulator System	9
3.1	Automatic Voltage Regulator "Parallel" Adjustment Procedure	9
3.2	Automatic Voltage Regulator Replacement Adjustment Procedure	10
3.3	Current Limiter Adjustment	13
4	Parts List	17
	Warranty	18
FIGURE	<u>CONTENT</u>	<u>PAGE</u>
2-1	Test Cable TS-1 Current Limiter Schematic	7
2-2	Test Cable TS-2 Cross Current Schematic	7
2-3	Cross Current Analyzer Schematic	8
3-1	Current Limiter Calibration Chart	16

CHAPTER 1
INTRODUCTION

The Cross Current Analyzer (CCA) provides current sources needed for troubleshooting and proper adjustment of the Current Limiter and Automatic Voltage Regulator's "PARALLEL" circuits.

During adjustment of replacement and or troubleshooting of Current Limiter, the CCA provides a current signal equal to that of the Current Transformers CT1, CT2 and CT3. The CCA is adjusted so that the output current level is equal to the level that would be present during a short circuit on the generator output terminals. The Current Limiter then can be adjusted for proper setting for each phase of limiter.

Proper adjustment of replacement Automatic Voltage Regulator's "PARALLEL" rheostat is made possible with Cross Current Analyzer. The CCA provides a current source that is phased to the generator line voltage, making the AVR think that the generator is being loaded with reactive load. The Parallel setting can easily adjusted because a know valve for the reactive load is being applied.

The AVR's "PARALLEL" rheostat sets the circuit than provides load sharing of reactive current between generators operated in parallel. This circuit can be operated in the Droop or Differential (Cross Current) modes as selected at console or switchgear. Proper adjust is needed to provide equal load sharing over the range of no load to full load operation of generators.

The complete procedure for adjustment of replacement Automatic Voltage Regulator is included.

NOTE

The Redundant Voltage Regulator System (RVRS) for the DDG-51 is know as the EXCOP or Excitation Control Panel.

CHAPTER 2
GENERAL AND FUNCTIONAL DESCRIPTION

2.0 GENERAL.

The Cross Current Analyzer (CCA) provides current sources needed for trouble shooting and proper adjustment of the Current Limiter and Automatic Voltage Regulator's "PARALLEL" circuits of the RVRS. Cross Current Analyzer Part Number 509-00150-10 is used on the Redundant Voltage Systems for the Brushless DDG-51 AND AOE-6 Generators. Another CCA is available for the FFG Redundant Voltage Regulator System. The CCA will be description will be divide into two sections. Section One will cover Cross Current used to set "PARALLEL" on the AVR. With Section Two covering the Current Limiter power supply circuitry.

2.1 SECTION ONE - CROSS CURRENT.

This section (Cross Current) of the CCA provides current and voltage signals to the AVR, that are phased to represent reactive loading of the Generator. This makes calibration of the AVR's "PARALLEL" rheostat possible without the use of reactive load banks.

The Cross Current section parts that visual on front panel are as follows: Cross Current Connection TS-2 (bottom connector of two in upper right hand corner), three Fuseholders L1, L2 and L3 (middle left hand side), 450 VAC Test Points

The following is a functional description of circuitry in the CCA (Figure 2-3) and Test Cable TS-2 (Figure 2-2).

Test Cable TS-2 is used to connect the CCA, into the Redundant Voltage Regulator System at plug P32 on Interface Module. (See Chapter Three for connection details.) This connection provides for the 450 sensing voltage, shorts the output of current transformer CCT1 in Interface Module and connect for output of Cross Current section to AVR's through the Failure Detector Module.

The three Voltage Sensing lines are fused with 1 amp, 600 volt fuses (L1, L2 and L3). From the fuses the voltage is feed to a transformer T2 and test points TP4-L1, TP4-L2 and TP4-L3 used to monitor Generator output voltage. Transformer T2 connected across phases L1 to L3, steps down the voltage from 450 to 120 VAC sensing. Switch SW2 ("CROSS CURRENT") controls the on-off of sensing to this section, with amber indicator POL2 providing a visual indication when sensing is on. The 120V sensing voltage is applied to the output pins through resistor R4 and rheostat R9, These resistances control the current levels in the Cross Current circuit. Resistance R4 is used to set the maximum current allowed, whenever R9 is at its minimum resistance value. Rheostat R9, the "CROSS CURRENT LEVEL" provides adjustment of current level as required by set-up procedure.

The Cross Current Ammeter (0-100 ma) and Shunt (100 Ma = 100 mv ac) is provided for monitoring the current being applied to Automatic Voltage Regulator. The Ammeter is for functional use only, is not calibrated for actual reading during calibration of AVR. The output of the Cross Current Shunt at test points TP3 Red and Black are for use in conjunction with digital multimeter in the milli-volts AC scale. This provides for proper measurement of current level during the calibration process.

2.2 SECTION TWO - CURRENT LIMITER.

This section (Current Limiter) of the CCA provides current signals to the Current Limiter that would be present during a short circuit of the Generator output terminals. This current signal make is used to determine proper operation and or calibrate the output for each phase of CL.

The following is a functional description of Current Limiter section circuitry in the CCA (Figure 2-3) and Test Cable TS-1 (Figure 2-1).

Test Cable TS-1 is used to connect the CCA, into the Redundant Voltage Regulator System at plug P6 on the Interface Module. (See Chapter Three for connection details.) This connection provides for output of CCA to be feed to the CL, shorts the output of current transformers in CT1, CT2 and CT3, and provides for connection of CL output signal to Interface Module.

Power for the Current Limiter section of the CCA is 120 VAC power from an outlet. The power cord is connected to the 120 V AC, 60 Hz plug on the lower right -hand corner. Switch SW-1 the "Current Source" controls on-off of the circuit. Power is feed through fuse FU-1 (120 VAC, 9 AMP) to red indicator POL1 and step-down transformer T1 reducing the voltage level from 120 to 6. The 6 volts is applied to the output connector pins (TS-1) as selected by SW-3 Phase Selector. Resistor R2 and rheostat R8 control the current levels in the current limiter circuits. Resistor R8 sets the maximum current allowed, whenever R8 is at minimum resistance value. Rheostat R9, the "Current Source Level" provides adjustment of current level as required by set-up procedure.

The Current Source Ammeter (0-20 AMP) and Shunt (20 AMP = 200 mv ac) is provided for monitoring the current being applied to Current Limiter. The Ammeter is for functional use only, is not calibrated for actual reading during calibration of AVR. The output of the Current Source Shunt at test points TP2 Red and Black are for use in conjunction with digital multimeter in with milli-volts AC. This provides for proper measurement of current level during the calibration process. The Current Limit Output Voltmeter (0-30 VDC) and Test Points TP1 provides for monitoring of Current Limiter DC voltage output. The Voltmeter is for functional use only, is not calibrated for actual reading during calibration of CL. The output of the Current Limit Output at test points TP1 Red and Black are for use in conjunction with digital multimeter in DC

voltage scale. This provides for proper measurement during the calibration process.

Phase Selector switch SW-3 provides for switching of current to each of the three phases of the Current Limiter. The Phase Selector provides for testing of Current Limiter when installed in the Redundant Voltage Regulator System in "System Test A, B and C" positions or for testing on the bench or outside panel by using the " Bench Test A, B and C" positions.

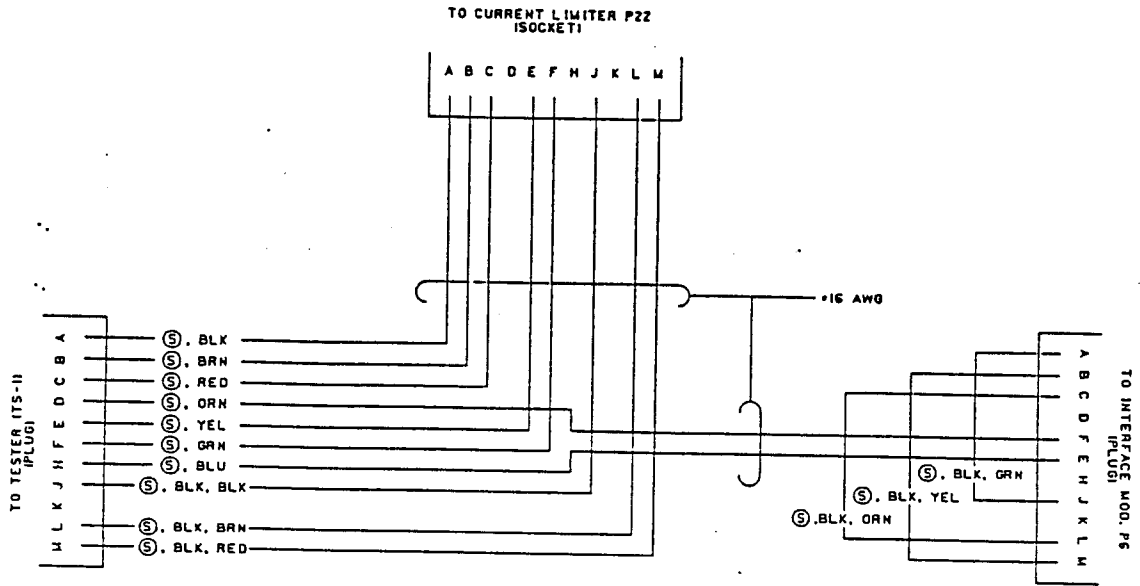

FIGURE 2-1 TEST CABLE TS-1 CURRENT LIMITER SCHEMATIC

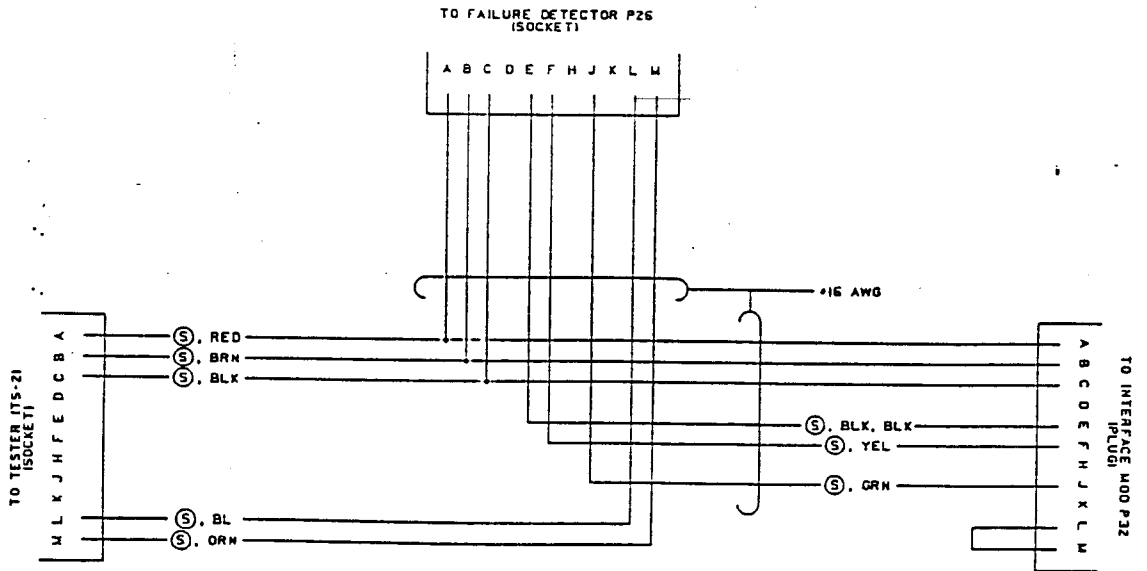
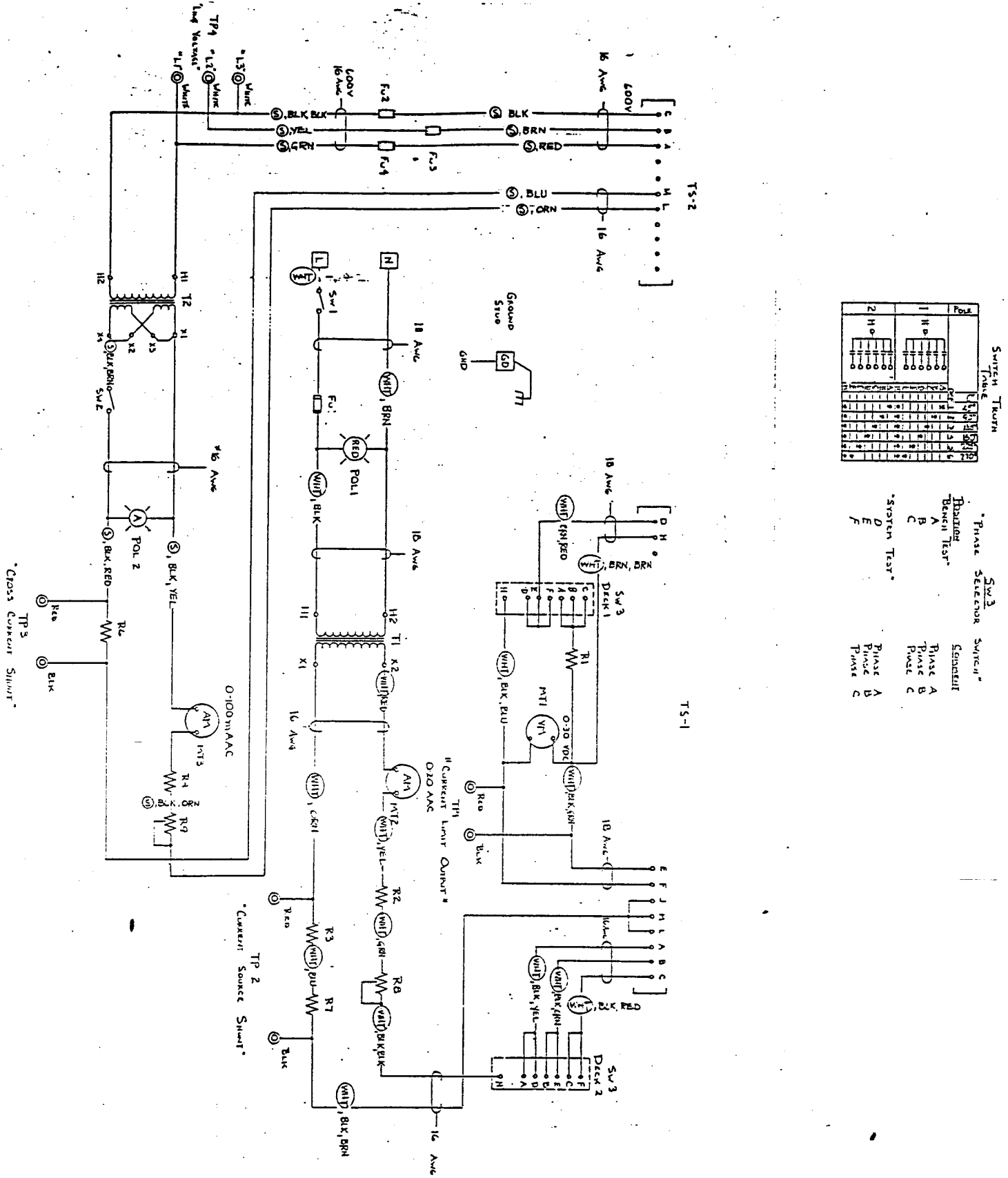

FIGURE 2-2 TEST CABLE TS-2 CROSS CURRENT SCHEMATIC



SW3
 "Phase Selector Switch"

Phase	Terminal	Color
A	1	RED
B	2	BLK
C	3	YEL
A	4	RED
B	5	BLK
C	6	YEL
A	7	RED
B	8	BLK
C	9	YEL
A	10	RED
B	11	BLK
C	12	YEL

SW2
 "System Test"

Phase	Terminal	Color
A	1	RED
B	2	BLK
C	3	YEL
A	4	RED
B	5	BLK
C	6	YEL
A	7	RED
B	8	BLK
C	9	YEL
A	10	RED
B	11	BLK
C	12	YEL

FIGURE 2-3 CROSS CURRENT ANALYZER SCHEMATIC

CHAPTER 3
AUTOMATIC VOLTAGE REGULATOR ADJUSTMENTS

3.1 AUTOMATIC VOLTAGE REGULATOR "PARALLEL" ADJUSTMENT PROCEDURE.

NOTE

DDG-51 uses an Excitation Selector Switch (ESS) to select mode of operation. Whereas the AOE-6 uses a Voltage Regulator Mode Switch (VRMS) for the same purpose. Both systems use the Primary Selector Switch (PSS) to select voltage regulator running as primary.

- a. With Generator at standstill, switch to the "OFF" position on the ESS (VMRS).
- b. Open cover of FDM, using a jumper with mini-chips connect TP-G to TP-18 on Failure Detector Module Circuit Board Assembly.

NOTE

Jumpering from TP-G to TP-18 on FDM circuit board disables the FDM so the system remains on the primary AVR.

- c. Connect Cross Current Analyzer (Kato PN 509-00150-10) to RVRS (EXCOP) using the following procedure.
 1. Locate and disconnect cable from plug P32 on IFM.
 2. Install the Test Cable TS-2 from Cross Current Analyzer plug marked TS-2 CROSS CURRENT CONNECTION to plug P32 on IFM and cable from off of plug P32.
 3. Place the Analyzer CROSS CURRENT switch in "OFF", rotate CROSS CURRENT LEVEL knob counter-clock wise to 0.
 4. Connect one digital multi-meter (4 1/2 digit) set-up to measure AC voltage, Range 0.0 to 600.0 ACV across test points TP4 L1 to L3 on Analyzer. Connect another digital multi-meter (3 1/2 digit) set-up to measure AC Millivolts, Range 0 to 100 (or 200) AC mv across test points TP3 (Red to Black).
- d. Verify proper connection of Power and Sensing cables to AVR.
- e. Remove Cap Lock Nut from PARALLEL rheostat mounted on the cover of the AVR to adjusted.
- f. Preset Parallel adjustments fully counter-clock wise.
- g. Operate Generator Set at rated frequency. Switch PSS to select AVR to be adjusted as Primary AVR.
- g. To adjust the PARALLEL adjustment on the AVR, using the Cross Current Analyzer perform the following procedure.

1. Verify Analyzer CROSS CURRENT power switch is in "OFF" position.
 2. Select AVR to be adjusted as primary with the PSS switch, switch ESS (VMRS) to "AUTO".
 3. Measuring Generator output voltage at TP4 L1 to L3 on Analyzer, set voltage to 450.0 ACV using Voltage Raise-Lower Switch (VRLS).
 4. Switch "ON" the CROSS CURRENT power, adjust CROSS CURRENT rheostat to 30.0 AC mv across TP3 (Red to Black).
 5. Adjust the PARALLEL rheostat in clockwise direction, lowering generator output voltage to 437.5 ACV, while maintaining TP3 at 30.0 AC mv by adjusting CROSS CURRENT LEVEL.
 6. Verify that Generator Output Voltage is at 450.0 ACV when CROSS CURRENT is "OFF" and at 437.5 ACV when TP3 reads 30.0 AC mv.
 7. With CROSS CURRENT "ON", verify that replace and tighten of PARALLEL lock nut doesn't change setting by observing generator output voltage.
- h. Shutdown Generator Set, place ESS (VMRS) in "OFF" position. Disconnect test cable TS-2 from plug P32 and reconnect cable connector P32.
- i. Remove jumper from TP-G to TP-18 on FDM circuit board that disables the FDM.
- i. Select replacement (or adjusted) AVR as "PRIMARY AVR", switch ESS (VMRS) to "AUTO". Operate Generator Set in single unit configuration, then in parallel with other units to verify proper operation of set.

3.2 AUTOMATIC VOLTAGE REGULATOR REPLACEMENT ADJUSTMENT PROCEDURE.

This procedure provides for adjustment of replacement Automatic Voltage Regulators to provide proper operation and setting.

NOTE

The adjustment procedure for AVR1 and AVR2 are similar with the exception of the rheostat in Failure detector module used to set voltage output level. Rheostat R70 is used for fine adjustment of generator output voltage for AVR1, whereas R71 is used for adjustment of AVR2.

- a. With Generator at standstill, switch to the "OFF" position on the ESS (VMRS).

- b. Open cover of FDM, using a jumper with mini-chips connect TP-G to TP-18 on Failure Detector Module Circuit Board Assembly.

NOTE

Jumpering from TP-G to TP-18 on FDM circuit board disables the FDM so the system remains on the primary AVR.

- c. Connect Cross Current Analyzer (Kato PN 509-00150-10) to RVRS (EXCOP) using the following procedure.
 1. Locate and disconnect cable from plug P32 on IFM.
 2. Install the Test Cable TS-2 from Cross Current Analyzer plug marked TS-2 CROSS CURRENT CONNECTION to plug P32 on IFM and cable from off of plug P32.
 3. Place the Analyzer CROSS CURRENT switch in "OFF", rotate CROSS CURRENT LEVEL knob counter-clock wise to 0.
 4. Connect one digital multi-meter (4 1/2 digit) set-up to measure AC voltage, Range 0.0 to 600.0 ACV across test points TP4 L1 to L3 on Analyzer. Connect another digital multi-meter (3 1/2 digit) set-up to measure AC Millivolts, Range 0 to 100 (or 200) AC mv across test points TP3 (Red to Black).
- d. Verify proper connection of Power and Sensing cables to AVR.
- e. Remove Cap Lock Nuts from STABILITY, RANGE and PARALLEL rheostat mounted on the cover of the AVR to be adjusted.
- f. Adjust STABILITY by first rotating rheostat fully counter-clock wise with screwdriver. One end of the screwdriver slot should pointed at approximately 4 O'clock, this end is to act as the pointer. Set STABILITY by rotating pointer clockwise to 12 O'clock. Replace Cap Lock Nut and tighten to lock rheostat.
- g. Preset RANGE and Parallel adjustments to fully counter-clock wise.
- h. Operate Generator set at rated frequency. Select AVR with PSS select AVR that was not a replacement, switch ESS (VMRS) to "AUTO". Measure and record Generator output voltage across TP4 L1 to L3 on Analyzer. (The output voltage should be approximately 450 volts plus or minus 2.)
- i. Switch PSS to select AVR to be adjusted as Primary AVR. Observe that voltage is controlled at a value less than normal but is stable. If AVR goes into an over voltage condition, see Troubleshooting section on Automatic--Switches to Standby AVR In Control.

- j. The procedure for adjustment of Range is broken into two sections. Section 1 is adjustment of AVR1, with section for AVR2. Measure Generator output voltage level on Analyzer at test points TP4 L1 to L3.

NOTE

The adjustment procedure for AVR1 and AVR2 are similar with the exception of the rheostat in Failure detector module used to set voltage output level. Rheostat R70 is used for fine adjustment of generator output voltage for AVR1, whereas R71 is used for adjustment of AVR2.

1. To adjust the RANGE rheostat on AVR1, perform the following procedure.
 - a. Locate rheostat R70 on the FDM circuit board, after loosening lock nut, rotate rheostat fully clockwise.
 - b. Using RANGE adjust on AVR set generator output voltage at a level 3 volts higher than the voltage measured for other AVR in step h (approximately 453 ACV). Replace and tighten Cap Lock Nuts on RANGE adjust on AVR.
 - c. Using R70 in FDM, adjust generator output voltage to within plus or minus 0.1 volts of voltage measure in step h. Tighten lock nut on R70 in FDM, verify that output voltage doesn't change during tightening.
 2. To adjust the RANGE rheostat on AVR2, perform the following procedure.
 - a. Locate rheostat R71 on the FDM circuit board, after loosening lock nut, rotate rheostat fully clockwise.
 - b. Using RANGE adjust on AVR set generator output voltage at a level 3 volts higher than the voltage measured for other AVR in step h (approximately 453 ACV). Replace and tighten Cap Lock Nuts on RANGE adjust on AVR.
 - c. Using R71 in FDM, adjust generator output voltage to within plus or minus 0.1 volts of voltage measure in step h. Tighten lock nut on R70 in FDM, verify that output voltage doesn't change during tightening.
- k. To adjust the PARALLEL adjustment on the AVR, using the Cross Current Analyzer perform the following procedure.
1. Verify Analyzer CROSS CURRENT power switch is in "OFF" position.
 2. Select AVR to be adjusted as primary with the PSS switch, switch ESS (VMRS) to "AUTO".

3. Measuring Generator output voltage at TP4 L1 to L3 on Analyzer, set voltage to 450.0 ACV using Voltage Raise-Lower Switch (VRLS).
 4. Switch "ON" the CROSS CURRENT power, adjust CROSS CURRENT rheostat to 30.0 AC mv across TP3 (Red to Black).
 5. Adjust the PARALLEL rheostat in clockwise direction, lowering generator output voltage to 437.5 ACV, while maintaining TP3 at 30.0 AC mv by adjusting CROSS CURRENT LEVEL.
 6. Verify that Generator Output Voltage is at 450.0 ACV when CROSS CURRENT is "OFF" and at 437.5 ACV when TP3 reads 30.0 AC mv.
 7. With CROSS CURRENT "ON", verify that replace and tightening of PARALLEL lock nut doesn't change setting by observing generator output voltage.
- l. Shutdown Generator Set, place ESS (VMRS) in "OFF" position. Disconnect test cable TS-2 from plug P32 and reconnect cable connector P32.
 - m. Remove jumper from TP-G to TP-18 on FDM circuit board that disables the FDM.
 - n. Select replacement (or adjusted) AVR as "PRIMARY AVR", switch ESS (VMRS) to "AUTO". Operate Generator Set in single unit configuration, then in parallel with other units to verify proper operation of set.

3.3 CURRENT LIMITER ADJUSTMENTS.

This procedure provides for adjustment of replacement Current Limiter to assure proper setting of module for overall system performance.

- a. With Diesel at standstill, switch to the "OFF" position on the ESS (VRMS).
- b. Open cover of FDM, using a jumper with mini-chips connect TP-G to TP-18 on Failure Detector Module Circuit Board Assembly.

NOTE

Jumpering from TP-G to TP-18 on FDM circuit board disables the FDM so the system remains on the primary AVR.

- c. Connect Cross Current Analyzer (Kato PN 509-00150-10) to RVRS (EXCOP) using the following procedure.
 1. Locate and disconnect cable from plug P6 on IFM.

PUBLICATION: 351-09002-00
PUBLICATION DATE: DECEMBER 1991

2. Install the Test Cable TS-1 from Cross Current Analyzer plug marked TS-1 CURRENT LIMITER CONNECTION to plug P6 on IFM and cable from off of plug P6.
 3. Locate and disconnect cable from plug P32 on IFM.
 4. Install the Test Cable TS-2 from Cross Current Analyzer plug marked TS-2 CROSS CURRENT CONNECTION to plug P32 on IFM and cable from off of plug P32.
 5. Place the Analyzer CROSS CURRENT switch in "OFF", rotate CROSS CURRENT LEVEL knob counter-clock wise to 0.
 6. Connect one digital multi-meter set-up to measure AC volts, Range 0 to 600 ACV across test points TP4 L1 to L3 on Analyzer. Connect another digital multi-meter set-up to measure AC Millivolts, Range 0 to 200 AC mv across test points TP2 (Red to Black).
 7. With the Analyzer CURRENT SOURCE switch in "OFF", plug Analyzer in 120 ACV power outlet. Place rotary PHASE SELECTOR switch in SYSTEM TEST - A PHASE. Rotate CURRENT SOURCE LEVEL knob counter-clock wise to 0.
- d. Remove Cap Locking Nuts and preset rheostats on cover of CL marked PHASE A, PHASE B and PHASE C to full clockwise position.
 - e. Operate Diesel Generator set at rated voltage with ESS (VRMS) in "AUTO".
 - f. Measuring Generator output voltage at TP4 L1 to L3 on Analyzer, set voltage to 450.0 ACV using Voltage Raise-Lower Switch (VRLS).
 - h. Switch CURRENT SOURCE switch to "ON", PHASE SELECTOR on SYSTEM TEST PHASE A. Slowly increase output by turning CURRENT SOURCE LEVEL knob on Analyzer, increase level until 130 AC mv is measured across TP2 (Red to Black).
 - i. Adjust the Current Limit PHASE A rheostat per the following procedure.
 1. Rotate the rheostat in a counter clockwise direction until generator output voltage is decreases to 448.0 ACV, while maintaining TP2 at 130.0 AC mv by adjusting CURRENT SOURCE LEVEL.
 2. Verify that Generator Output Voltage is at 450.0 ACV when CURRENT SOURCE is "OFF" and at 448.0 ACV when TP2 reads 130.0 AC mv.

3. With CURRENT SOURCE "ON", verify that replace and tightening of Cap Lock Nut doesn't change setting by observing generator output voltage.
- j. Repeat step i for PHASE B and PHASE C rheostats with the PHASE SELECTOR switch in the appropriate SYSTEM TEST PHASE B or PHASE C position.
- k. Shutdown Diesel Generator set, place ESS (VRMS) in "OFF" position. Disconnect test cables TS-1 and TS-2 from plugs P6 and P32, then reconnect cable connectors P6 and P32.
- l. Remove jumper from TP-G to TP-18 on FDM circuit board that disables the FDM, when trouble shooting is completed.
- m. Return Diesel Generator set into service.
- n. Operate the generator at rated voltage with available ships load.
- o. Measure and record the DC Voltages (0 to 10 volt range) across test points TP-D to TP-A, TP-B and TP-C mounted on cover of CL. At the same time reading for test points are recorded, measure and record generator output current.
- p. Compare reading with Current Limiter Calibration Chart Figure 3-1 or Current Limiter Calibration Chart in technical manual, if reading outside tolerance, redo adjustment procedure.

NOTE

If no signals can be found at CL test points CL, check wiring running to current transformer and CT Overvoltage Protection from RVRS (EXCOP) to Generator for proper connection.

C O U R T E S Y O F G E N E R A L E L E C T R I C

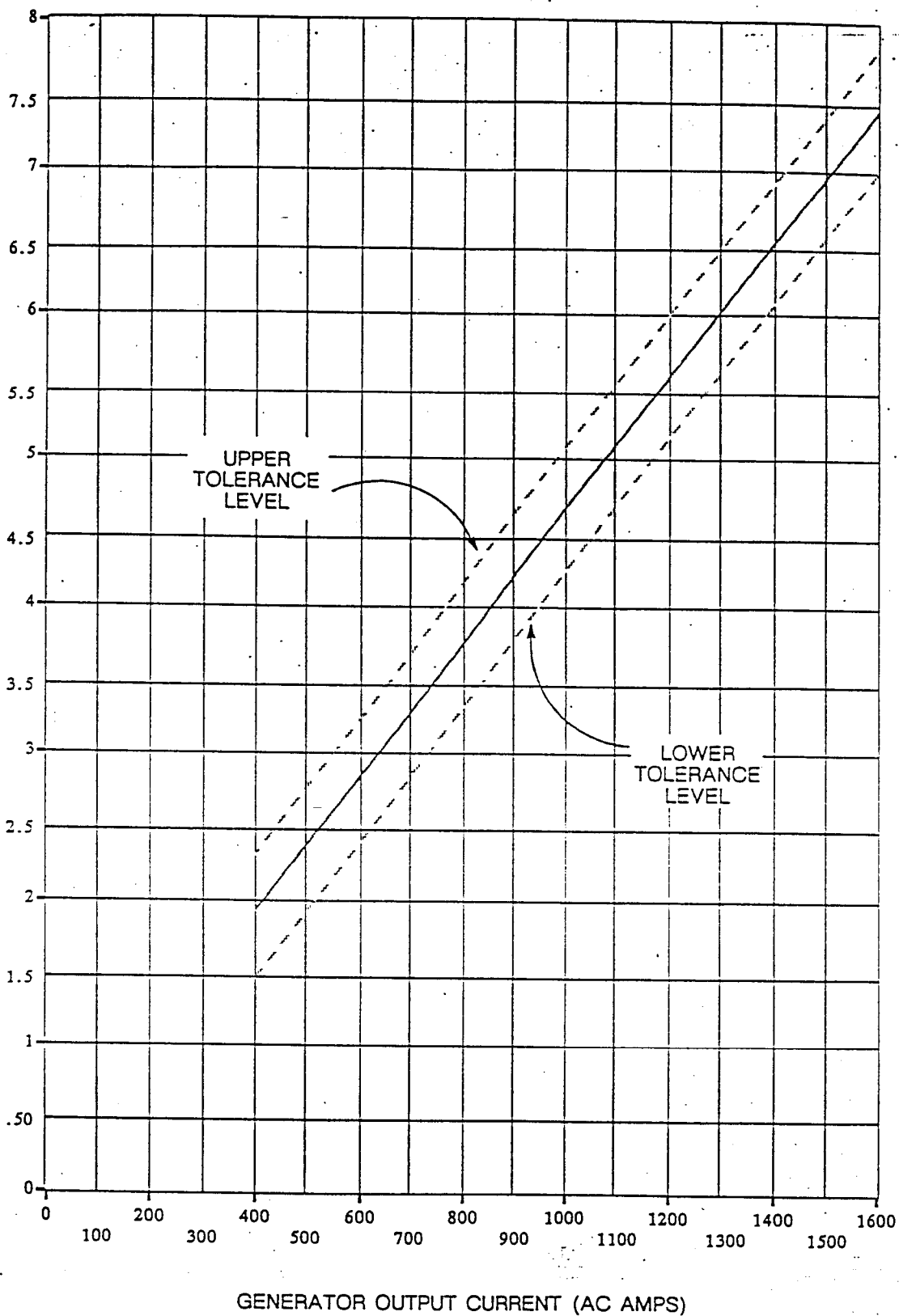

FIGURE 3-1 CURRENT LIMITER CALIBRATION CHART.

CHAPTER 4
PARTS LIST

RENEWAL PARTS ORDERING INFORMATION

Renewal parts must be of the same physical construction and have the same operating characteristics as parts installed in the Voltage Regulator System at the factory. Do not attempt to substitute "similar" parts.

Order parts by part name and part number. As additional information, always include the generator serial number.

For fastest service direct parts order to:

KATO ENGINEERING
Parts and Service Department
P. O. Box 47
Mankato, Minnesota 56001

or call (507) 625-4011 FAX. (507)-345-2798 TLX 29- 0786.

PART NUMBER	QUANTITY PER ASSEMBLY	DESCRIPTION
509-00150-10	1	Cross Current Analyzer
514-90003-50	1	Test Cable TS-1 Current Limiter
514-90003-51	1	Test Cable TS-2 Cross Current
514-08445-99	1	Power Cable, 120 VAC
515-02209-11	1	Fuse, ACG-9, 9 amp., 250 V.
515-06201-51	3	Fuse, KTK-1, 1 amp., 600 V.
550-00766-12	1	DC Voltmeter, 0-30 VDC.
551-00792-91	1	AC Ammeter, 0-10 AMP
551-01579-11	1	AC Ammeter, 0-100 ma

WARRANTY

Kato Engineering warrants that its products will perform as specified in bonafide quotations or Kato publications, providing such products are properly installed, properly cared for, and properly operated under normal environmental conditions.

Standard products manufactured by Kato Engineering are warranted to be free from defects in workmanship and material for a period of one year in operation or 18 months from date of shipment, and any products which are defective in workmanship or material will be repaired or replaced at the option of Kato Engineering. Final determination as to whether a product is actually defective rests with Kato Engineering. The obligation of Kato Engineering Hereunder shall be limited solely to repair and replacement at its factory, of products that fail within the foregoing limitations and shall be conditioned upon receipt by Kato Engineering of written notice within the warranty period of any alleged defects or deficiency. No products shall be returned to Kato Engineering without its prior consent. In no case will Kato Engineering accept shipping charges incurred either through return of defective items to its factory or return of repaired or replacement items to the user. Kato Engineering cannot assume responsibility or accept invoices for unauthorized repairs to its components even though defective. In the case of components, parts or units purchased by Kato Engineering the obligation of Kato Engineering shall not exceed the settlement that is able to obtain from the supplier thereof. The life of the products of Kato Engineering depends to a large extent upon the type of usage. Kato Engineering makes no warranty as to period of service nor as to fitness of its products for specific applications by the buyer. In no event will Kato Engineering be liable for consequential or incidental damages or any expense incurred by the Buyer due to use or sale of products sold by Kato Engineering.

The foregoing warranty is exclusive and in lieu of all other warranties expressed or implied, including but not limited to any warranty of merchantability or of fitness for a particular purpose.

This Warranty does not apply to experimental or developmental products.

PO Box 47 / Mankato, MN USA 56001 (507)625-4011 TLX:29-0786/1/83
Fax (507)345-2798

KATO ENGINEERING / RELIANCE ELECTRIC

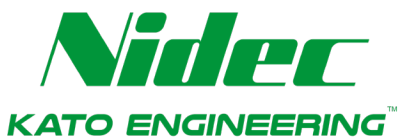

Kato Engineering Support

The brand you trust, the power you depend on. Include the serial number and model number for your machine in the email subject line.

Field Service	KatoService@mail.nidec.com
Parts	KatoParts@mail.nidec.com
Remanufacturing	KatoRemanufacturing@mail.nidec.com
Warranty/Quality Assurance	KatoWarranty@mail.nidec.com