

The JF model is designed as a “slimline” for compact product envelops. The JF series of gearmotors was designed for quiet, versatile, and dependable performance.

SPECIFICATIONS & CONSTRUCTION

Type: Zinc die cast AC gearmotor
Output speeds: 40 to 250 RPM
Voltage: 24V to 230V, 50 or 60 Hz
Bearings: Self-aligning sintered bronze
Termination: Spade terminals or lead wires
Protection: Impedance or thermally protected
Duty Cycle: Intermittent
Motors Available: 3400, 3700, 4400, 4500
Rotation: Unidirectional; PSC-Reversing (JFS)
Cover: Stamped Steel
Lubrication: Synthetic Grease
Regulatory Approvals: UL, CSA, CE, RoHs



JFS 3400

TYPICAL APPLICATIONS

- RV De-reeler
- Banking Equipment
- Instrumentation
- Crane Games
- Food Service Equipment
- Pumps

Maximum Permissible Torque: 30 In.Lb (3.4 Nm)
Speed: Up to 250 RPM

Note: Speed and torque combinations will vary depending on the motor/gearbox combination.

OPTIONAL FEATURES

- Customized output shafts including dual output
- Various lead lengths, terminals and connectors
- Brakes: Positive-Stop, Cone, Coil Spring
- Output Needle bearings for high radial loads
- Ball bearing for motor
- Fan for additional cooling

MOUNTING

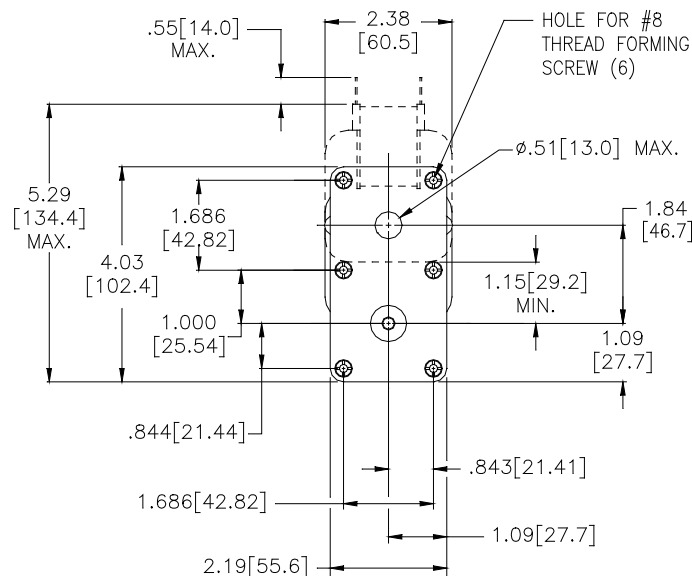

STAMPED STEEL CO

JF3700

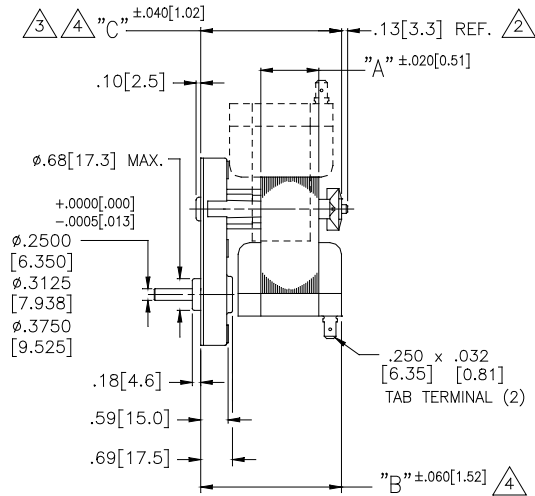

STATOR SIZE	"A" DIM	"B" DIM	"C" DIM
3709	.575[14.61]	2.394[60.81]	2.361[59.97]
3715	.937[23.80]	2.756[70.00]	2.723[69.16]
3720	1.250[31.75]	3.069[77.95]	3.036[77.11]
3724	1.500[38.10]	3.319[84.30]	3.286[83.46]
3728	1.760[44.70]	3.579[90.91]	3.546[90.07]
3732	2.000[50.80]	3.819[97.00]	3.786[96.16]

NOTES:

- BROKEN LINES REPRESENT OPTIONAL MOUNTINGS.
- FOR FAN APPLICATION, ADD .600[15.24] TO DIMENSION. FOR COIL SPRING BRAKE APPLICATION, ADD .060[1.52] TO DIMENSION.
- FOR COIL SPRING BRAKE APPLICATION, ADD .188[4.78] TO "C" DIMENSION.
- FOR LONG MOUNTING APPLICATION, SUBTRACT .188[4.78] FROM "B" & "C" DIMENSION.

JF4500

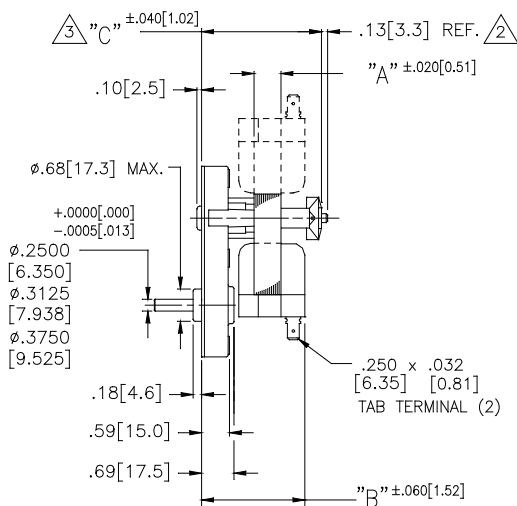

STATOR SIZE	"A" DIM	"B" DIM	"C" DIM
4506	.375[9.53]	1.996[50.70]	1.973[50.11]
4509	.562[14.27]	2.183[55.45]	2.160[54.86]
4512	.733[18.62]	2.354[59.79]	2.331[59.21]
4515	.937[23.80]	2.558[64.97]	2.535[64.39]
4520	1.275[32.39]	2.896[73.56]	2.873[72.97]
4526	1.625[41.28]	3.246[82.45]	3.223[81.86]

NOTES:

- BROKEN LINES REPRESENT OPTIONAL MOUNTINGS.
- FOR FAN APPLICATION, ADD .600[15.24] TO DIMENSION. FOR COIL SPRING BRAKE APPLICATION, ADD .060[1.52] TO DIMENSION.
- FOR COIL SPRING BRAKE APPLICATION, ADD .188[4.78] TO "C" DIMENSION.



JFS3400

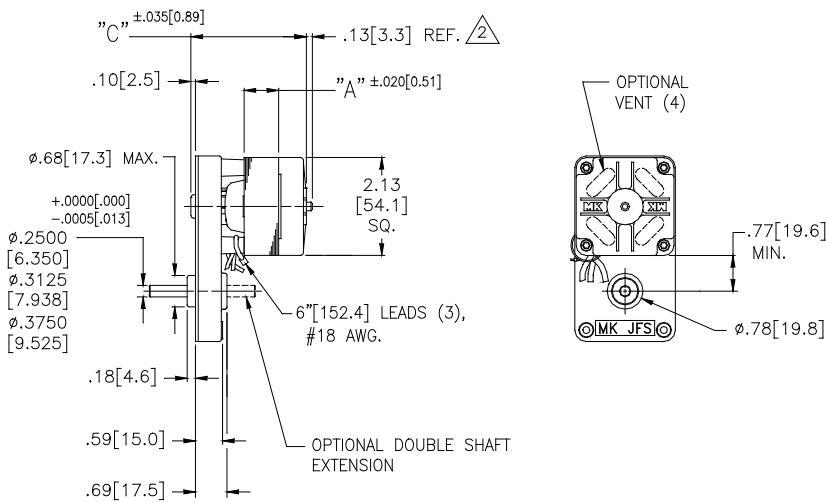

STATOR SIZE	"A" DIM	"C" DIM
3410	.625[15.88]	2.275[57.79]
3420	1.250[31.75]	2.900[73.66]
3424	1.500[38.10]	3.150[80.01]

NOTES:

- BROKEN LINES REPRESENT OPTIONAL MOUNTINGS.
- FOR FAN APPLICATION, ADD .600[15.24] TO DIMENSION.
FOR BRAKE APPLICATION, ADD .09[2.3] TO "C" DIMENSION.