

Worm gear reducers have a distinct advantage of having very low audible noise. The right angle output configuration results in a compact, low profile mounting. Extraordinary efficiency, relative to standard worm gear reducers, is achieved with the use of a custom-designed high-strength plastic worm wheel with optimized tooth profile. This special design allows the gearmotor to be easily back-driven. The high efficiency allows the use of a smaller, more energy efficient motor to achieve the same output power versus a standard worm gear reducer. The 5700B brushless motor offers extended life, high efficiency, and controllability for demanding applications.

GEAR REDUCER FEATURES

Gear Ratios: 10.25:1
Axial Load / Radial Load: 200 N / 250 N
Efficiency: 75 to 80 %
Housing: Die cast Zinc
Lubrication: Synthetic Grease
Output speeds: 50 to 400 RPM

MOTOR FEATURES

Type: Electronically Commutated
Voltage: 12Vdc to 32Vdc
Output Power: 45 to 140 Watts with External Drive
Phase Connection: 3 Phase Wye
Slot / Poles: 12 / 8
Rotor Magnets: High Energy skewed to reduce cogging
Insulation Class: F
Rotation: Reversible
Rotor Positioning: Three Hall Effect Sensors
Bearings: Ball

INTEGRAL CONTROL FEATURES

Type: Two quadrant trapezoidal programmable
Speed Control: 0 to 5Vdc or 0 to 10Vdc
Protection: Over current and over temperature
Braking: Dynamic
Programming Options: Acceleration, velocity, current limit
Tachometer Output: 2 Channels – 6 PPR

OPTIONAL FEATURES

- Customized output shafts including dual output
- Helical first stage gear for low audible noise
- Various lead lengths, terminals and connectors
- Output Needle bearings for high radial loads
- Integral motor control
- Brakes: Electromagnetic
- Encoders: Incremental Optical or Capacitive

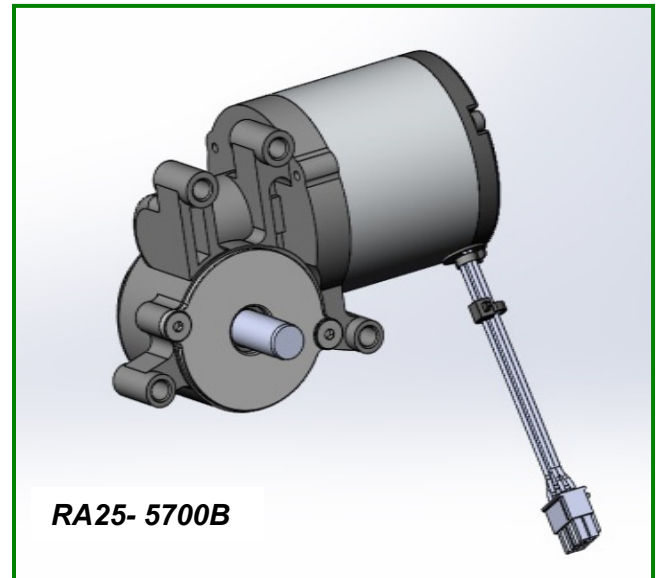

Maximum Permissible Torque: 35 In.Lb (3.0 Nm)
Speed: 50 to 400 RPM

Note: Speed and torque combinations will vary depending on the motor/gearbox combination.

TYPICAL APPLICATIONS

- Food Service Equipment
- Satellite positioning systems
- Pellet Stoves
- Agricultural Equipment
- Valve Actuators
- Medical / Laboratory Equipment
- Robotics
- Material Handling

RA25 GEAR REDUCER RATINGS

Data	Units	RA25
Gear Reduction	Ratio	10.25:1
Efficiency	%	80
Continuous Rated Torque	N.m	1.5
Maximum Permissible Torque	N.m	3.0
Axial /Radial Load	N	200/250

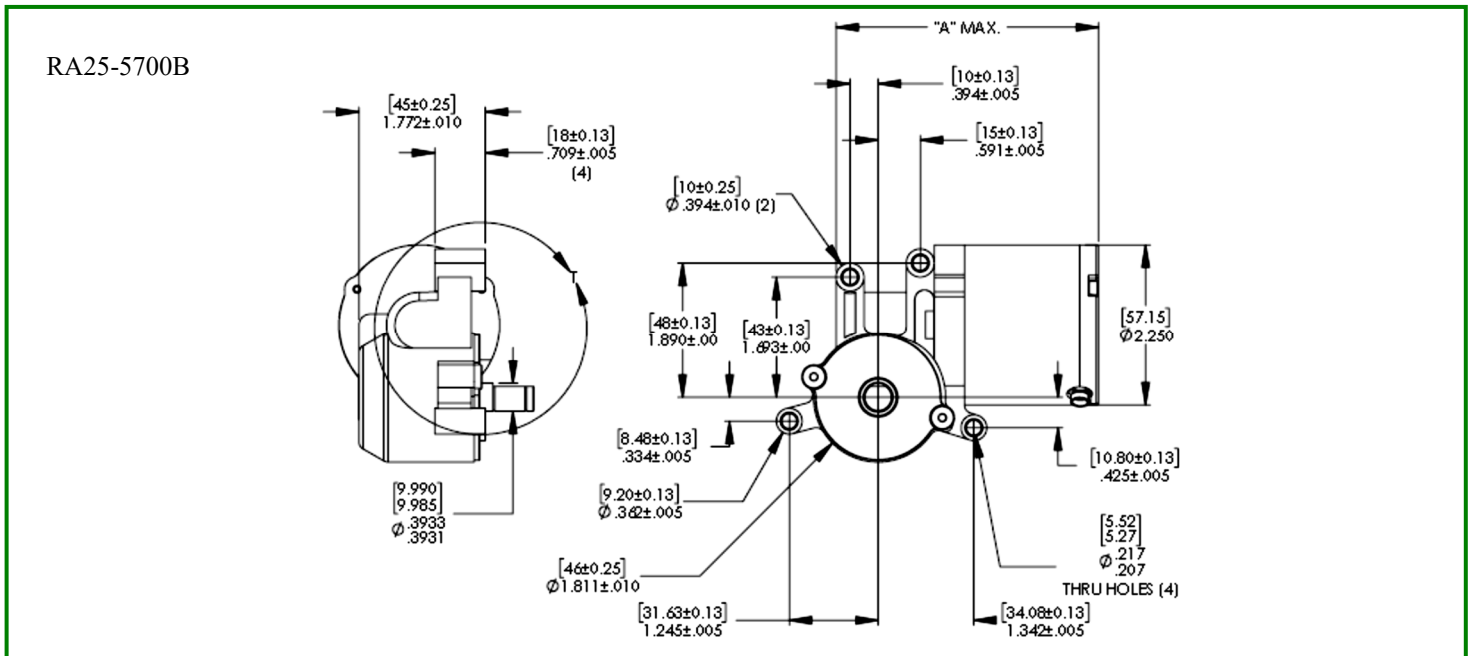

Model	Output Power (Watts) with Integral Control	Output Power (Watts) without Integral Control	Dimension "A"
RA25-5706B	12	45	3.230"[82.04]
RA25-5719B	25	100	3.730"[94.75]
RA25-5738B	45	140	4.480"[113.79]

Integral Controller: Lead Wire Color Code

Board Position	Designation	Lead Color
1	Digital I/O "A"	Gray
2	Digital I/O "B"	White/Red
3	Direction	White/Black
4	Signal Ground	Green
5	Enable Input	Orange
6	5 Vdc (output)	Yellow
7	Input Power (12-32Vdc)	Red
8	Power Ground	Black
9	Analog Input 2	Violet
10	Analog Input 1 (speed)	Blue
11	Tachometer Output "B"	Brown
12	Tachometer Output "A"	White

External Controller (Hall Only): Lead Wire

Board Position	Designation	Lead Color
1	Motor Phase A	Blue
2	Motor Phase B	White
3	Motor Phase C	Brown
4	Hall A	Green
5	Hall B	Orange
6	Hall C	Yellow
7	5 Vdc (Vcc)	Red
8	Ground	Black

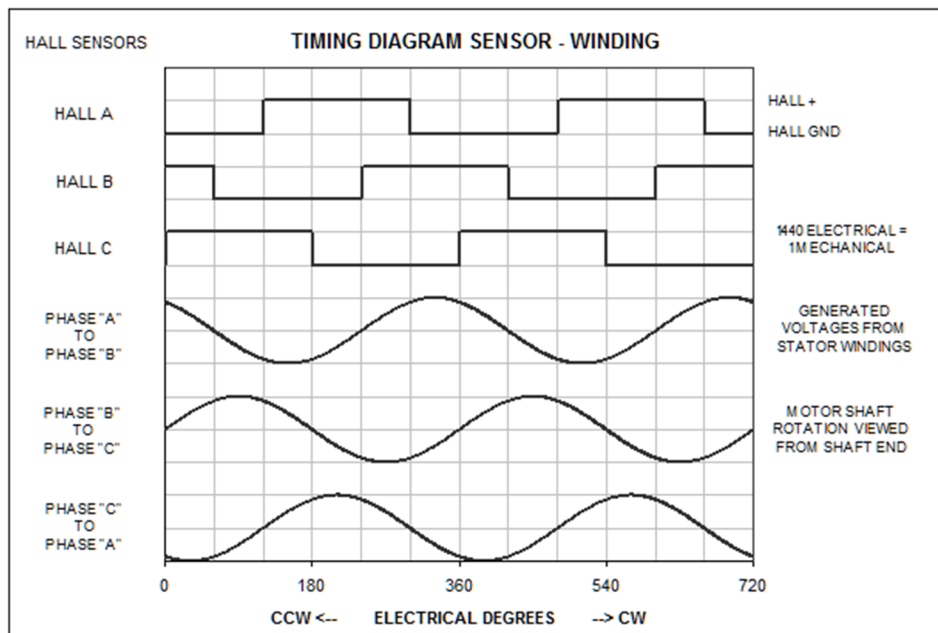

In order to properly commutate the Merkle-Korff 2.25" BLDC motor, the following table is provided to indicate the required motor phase state for a given hall-effect state.

Direction	120° Hall Spacing			Motor Phases		
	HA	HB	HC	MA	MB	MC
(NOTE 1)						
CW	1	0	0	DC+	OFF	DC-
	1	1	0	OFF	DC+	DC-
	0	1	0	DC-	DC+	OFF
	0	1	1	DC-	OFF	DC+
	0	0	1	OFF	DC-	DC+
	1	1	1	DC+	DC-	OFF
CW	1	0	0	DC-	OFF	DC+
	1	0	1	DC-	DC+	OFF
	0	0	1	OFF	DC+	DC-
	0	1	1	DC+	OFF	DC-
	0	1	0	DC+	DC-	OFF
	1	1	0	OFF	DC-	DC+

NOTE 1: Direction viewed from motor shaft (gearbox output shaft rotation may not be the same)