

MODIFIABLE PRICING INSTRUCTIONS

AERATOR ALTITUDE

1. AERATOR MOTOR - TYPE TVC-9, JVC-3

This specific purpose TEFC vertical solid shaft medium-thrust motor is available from 5 to 200 HP in single-speed (1800-1200-900 RPM) or multi-speed (1800/1200, 1800/900, 1200/900) designs. Features include all cast-iron construction (fan cover guard on Titan® motors is heavy fab steel) with CORRO-DUTY® protective treatments, a special sealant applied between the frame and register fit of each bracket, potted leads, a drain and breather in the low point of motor, Class F insulation and 1.15 SF. This product is shown prepriced in its single-speed form on page P-66 - P-68. Ratings not shown require review and approval of the Inquiry Group. When approved, use the TEFC VSS normal thrust price as a base and add 15% to include the above features on single-speed products. Also add per item 22 on page M-35 if multispeed is required. For available voltages, refer to item 53 on page M-78 of this section (multispeed motors are available as single voltage ratings only). Does not include special shafts. For special shafts, refer to item 38 on page M-49 of this section.

2. ALTITUDE

Standard motors are designed for 3300 feet altitude and 40°C ambient temperature. Atmospheric conditions at higher altitudes inhibit the motor's ability to dissipate heat, resulting in an increased temperature rise and a reduced motor capacity. NEMA standards state motor temperature will increase 1% for each 330-foot increment above the standard 3300-foot altitude design point. Ambient temperatures generally drop with an increase in altitude and are normally less than 40°C, even when installed indoors. Motors can be specifically designed for higher altitudes or derated, either due to lower ambient temperatures or by reducing output capacity.

- To maintain motor service factor in altitudes of 3301 to 9900 feet (1006 to 3018 meters), add per below:

FRAME SIZE	182	213	254	284	324	364	404	444	449
	184	215	256	286	326	365	405	447	
LIST PRICE	\$164	\$197	\$261	\$434	\$570	\$732	\$1,063	\$1,498	\$4,068

FRAME SIZE	5000	5800	6812 (TE)	6800-8000	9600
LIST PRICE	6%	6%	6%	6%	6%

- Altitudes above 9900 feet require mandatory review by the Inquiry Group. When approved, add 20% to the list price.
- DERATING FACTORS** -- Standard designs may be operated at the following altitude by reducing the output capacity of the motor by the derating factor shown. Does not apply to hazardous location. Nameplate will not acknowledge high-altitude use.

ALTITUDE (FT.)	DERATING FACTOR
3300-5000	0.97
5001-6600	0.94
6601-8300	0.91
8301-9900	0.88
9901-11500	0.85

- ADJUSTMENT DUE TO REDUCED AMBIENT TEMPERATURE** -- Standard designs may be operated at the following altitudes due to reduced ambient temperatures. Does not apply to hazardous location. Nameplate will not acknowledge high-altitude use.

MAXIMUM ALTITUDE IN FEET	AMBIENT (DEGREES C)
3300	40°C
6600	30°C
9900	20°C



† All marks shown within this document are properties of their respective owners.

MODIFIABLE PRICING INSTRUCTIONS



3. AMBIENT TEMPERATURE

Standard designs described in this catalog are suitable for operation in ambient temperatures ranging from +40°C (104°F) to -30°C (-22°F). When standard designs are consistently exposed to ambient temperatures between -5°C (23°F) and -30°C (-22°F), special lubrication practices may be required. Additional precautions such as space heaters and/or oil sump heaters may be required depending on such factors as starting methods and duty cycle. Clearly state low ambient requirements on inquiries to the Inquiry Group and order documents if product will be consistently exposed to -5°C to -30°C ambients.

NOTE: The minimum ambient temperature for standard hazardous location motors is -25°C. See ARCTIC DUTY for ambient temperatures below -25°C.

A. ARCTIC DUTY -- LOW AMBIENT APPLICATION

Available option for TEFC high-thrust, normal-thrust and in-line pump motors applied in ambients of -30°C (-22°F) to -56°C (-70°F). Add 25% to the list price to provide any required special electrical, lubrication and mechanical features (CORRO-DUTY® features are included). Hazardous location arctic duty vertical motors require mandatory review by the Inquiry Group. A nonreverse ratchet is not available on hazardous location arctic duty products. When approved by the Inquiry Group, add 25% to the hazardous location list price. Price does not include heaters for oil sump or motor winding.

**High tensile strength cast iron frame may be required. Refer to engineering for confirmation, if required add 225% to Standard Base list price.*

B. HIGH AMBIENT APPLICATION

To provide motors suitable for installation in ambient temperatures between 41°C and 65°C, make the list price addition shown below. Motor temperature rise will change from stated price book values with ambient temperatures above 40°C. Price book stated performance values, frame sizes and lubrication specifications are also subject to change. For confirmed data, refer to the Inquiry Group. For ambient temperature ratings over 65°C, check with Inquiry Group.

NEMA®† FRAME 41-65°C AMBIENT PRICE TABLE

FRAME SIZE	182	213	254	284	324	364	404	444	449
	184	215	256	286	326	365	405	447	
LIST PRICE	\$164	\$197	\$261	\$434	\$570	\$732	\$1,063	\$1,498	\$4,068

TITAN® FRAME 41-65°C AMBIENT PRICE TABLE

FRAME SIZE	5000-5800		6812	6800-9600
ENCLOSURE	OPEN	TEFC*	TEFC	OPEN
LIST ADDITION	12%	6%	12%	15%

**For hazardous location motors, obtain confirmed frame size from the Inquiry Group; price by frame and add 3% to the list price.*

Motors with oil lubricated thrust bearings will also require cooling coils for ambient temperature from 55°C - 65°C see cooling coils item 6.B.9 on M-10.

Motors with 1.15 SF may be derated to 1.0 SF for use in a 50°C ambient with no reduction in nameplate H.P. (Rated output). Non-hazardous location motors with 1.0 SF can be derated to accommodate ambient temperatures 40°C to 50°C by applying the following correction factors. Correction factors can be used, but actual performance will differ from published values.

Ambient Temperature	45°C	50°C
Rated Output reduced to	95%	90%



MODIFIABLE PRICING INSTRUCTIONS

BALANCE

4 BALANCE AND VIBRATION

NEMA standard MG1, Part 7, requires vibration readings to be measured in terms of velocity and stated as inches per second (IPS). Velocity is defined as the maximum speed at which displacement occurs. It takes into consideration both maximum displacement and time. To illustrate velocity, think of a point moving along a typical sine wave in a rising and falling fashion. As the point rises to its peak displacement (Point A), the velocity of movement is zero since it is about to change direction and must stop to do so. Changing direction, the point accelerates towards its peak displacement in the opposite direction (Point C). Midway between the peak displacement values (Point B), velocity is at its maximum. Since the velocity of motion is changing throughout its cycle, the highest peak is selected for measurement.

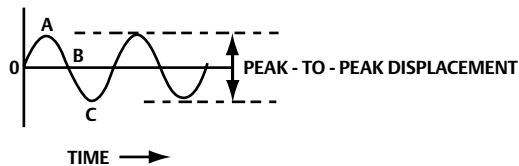

Nidec Motor Corporation balances all vertical motors to meet the standard limits shown below. For a refined balance, make the list adders indicated for normal, medium and high thrust motors.

VIBRATION LEVEL

	STANDARD	REFINED
Number of Poles	Velocity (IPS-PEAK)	Velocity (IPS-PEAK)
2	0.15	0.10
4	0.15	0.08
6	0.15	0.08
8	0.12	0.06
10	0.09	0.05
12	0.08	0.04

LIST PRICE ADDITION FOR REFINED BALANCE

THRUST RATING	182	213	254	284	324	364	404	444	449
	184	215	256	286	326	365	405	447	
NORMAL/MEDIUM	\$141	\$141	\$141	\$141	\$202	\$202	\$202	\$202	\$735
HIGH THRUST	\$282	\$282	\$282	\$282	\$404	\$404	\$404	\$404	\$1,467

FRAME RATING	5000	5800	6812 (TE)	6800-8000	9600
LIST PRICE	\$1,467	\$4,354	\$4,354	\$5,444	\$5,444



† All marks shown within this document are properties of their respective owners.

MODIFIABLE PRICING INSTRUCTIONS



5. BASE DIAMETERS

A. ADAPTER BASES, 449-6800 FRAME

Adapter or transition bases for 449TP through 6812VP frames call for review by the Inquiry Group due to their special requirements and impact on mechanical resonance. With approval, add as follows:

Frame Size	List Adder
449/5000	\$3,756
5800	\$5,634
6808-6812	\$7,518

Adapter brackets may impact delivery schedules.

B. NON-STANDARD BASES 6813 - 9600 FRAMES

6813, 8000 and 9600 frame standard P-base diameters are shown on the respective price book pages. Should the customer require a non-standard P-base diameter, add as follows (6813, 8000 and 9600 frames only).

Special lower brackets require review by the Inquiry Group prior to quotation as the weight may impact standard mechanical design.

Diameter	List Adder
46 to 49	\$3,756
50 to 55	\$5,282
56 to 60	\$11,737
61 to 65	\$15,023
66 to 71	\$19,484

For diameters over 71 inches, refer to the Inquiry Group.

6. BEARINGS

A. SPARE SET

A spare set of antifriction bearings can be ordered for modifiable motors only, when entered with the motor order. Add 7% to the base list price. For a spare plate bearing, refer to the Inquiry Group.



MODIFIABLE PRICING INSTRUCTIONS

BEARINGS

6. BEARINGS (continued)

B. BEARING LIFE

Customer specifications often require a vertical motor to meet a specific bearing life, normally stated in terms of hours or years. This time interval is further qualified as being either a minimum or average value.

The ABMA designation used to specify minimum bearing life is L-10 and is defined as the number of hours that 90% of a group of identical bearings will complete or exceed before the first evidence of fatigue develops. Average bearing life is designated as L-50 and is five times the L-10 life value.

Our price book thrust capacities are based on a 1 year L-10 or a 5 year average bearing life unless otherwise stated. Bearing life has an inverse relationship to our stated thrust capacities; that is, life will increase with a decrease in load or decrease with an increase in load. Therefore, in order to meet a specific bearing life, we must know the actual downthrust of the pump at design conditions. If the specification requires the life to be evaluated at the worst case condition, we would also need to know the shut-off thrust value.

To meet a specific bearing life, we must derate the price book values by a time factor. Example: 100HP, 1800 RPM, VHS WPI motor with a price book standard high-thrust capacity of 6700 lbs. is applied to a pump with a downthrust of 4415 lbs. The specification requires 40,000 hours minimum L-10 bearing life.

Step 1: Select the time factor from the list below for 40,000 hours L-10 (1.43).

Step 2: Divide motor thrust capacity by this value (6700/1.43). This yields the maximum allowable thrust value to meet 40,000 hours L-10. (4680 lbs. maximum D.T.)

Step 3: Compare actual requirement (5000 lbs.) to maximum allowable thrust value (4680 lbs.). If the actual load is less than the derated capacity, the motor meets the specification.

Step 4: If the actual load exceeds the derated capacity, extra high thrust (EHT) is required. To determine how much extra high thrust is required, multiply maximum allowable value (4680 lbs) by chosen EHT (175%) value. If this value equals or exceeds the actual condition, specification requirements are met. Add for 175% EHT.



MODIFIABLE PRICING INSTRUCTIONS



6. BEARINGS (continued)

VERTICAL MOTOR BEARING LIFE TIME FACTORS FOR ANTIFRICTION BEARINGS

Price book thrust capacities are based on 1 year minimum (L-10) or 5 year average (L-50) life.

L-10 Minimum Life		Thrust Capacity Time Factor	L-50 Average Life	
Years	Hours		Years	Hours
1	8800	1.00	5	44000
1.2	10560	1.04	6	52800
1.4	12320	1.08	7	61600
1.6	14080	1.12	8	70400
1.8	15840	1.15	9	79200
2	17600	1.18	10	88000
2.3	20000	1.22	11.5	100000
2.4	21120	1.23	12	105000
2.8	25000	1.28	14	125000
3	26400	1.30	15	132000
4	35200	1.37	20	176000
4.5	40000	1.43	22.5	200000
5	44000	1.47	25	220000
5.7	50000	1.51	28.5	250000
6	52800	1.53	30	264000
6.8	60000	1.58	34	300000
8	70400	1.64	40	352000
8.5	75000	1.67	42.5	375000
10	88000	1.73	50	440000
11.4	100000	1.78	57	500000



MODIFIABLE PRICING INSTRUCTIONS

BEARINGS

6. BEARINGS (continued)

B. BEARING LIFE

NOTES:

1. THESE VALUES APPLY ONLY TO ANTI-FRICTION (rolling element) bearings.
2. Statistically derived extended bearing life has certain limits beyond which it is no longer practical to add bearing capacity to increase life. Changing future conditions in the pump load will impact bearing life. Further, the user must maintain the product with care during storage, installation and operation.
3. Nidec Motor Corporation recommends the specifying engineer base the requirement upon the design life of the plant. By far, the most common plant design life is 20 years. From a conservative viewpoint, we recommend the following:

Plant Design Life	Minimum L-10	Average L-50
20 years	5 years	25 years
30 years	6.8 years	34 years
40 years	8.5 years	42.5 years

4. Nidec Motor Corporation uses IEEE 112 method B for our efficiency calculation of NEMA Nominal Efficiency. Increasing thrust capacity over stated standard high-thrust values to meet a specified bearing life will decrease motor full load efficiency at operating conditions due to the additional losses of larger capacity bearing arrangements. For 175% EHT, deduct 0.2 from efficiency values, for 300% EHT deduct 0.4 from efficiency values. For over 300% EHT, refer to the Inquiry Group. For a more accurate efficiency value for EHT motors, refer to the Inquiry Group.
5. 300% EHT requires spherical roller bearings of two-piece construction. Inherent to their design is a need for a minimum amount of downthrust to be applied at all times (refer to the Inquiry Group for values). Should a 300% EHT machine be applied to a pump driven by an inverter, care must be taken to insure this minimum downthrust load is present over the entire speed range. Otherwise, **severe non-warranty damage will result**. Pumps sized for future conditions are also subject to this problem.
6. Extended minimum bearing life has no impact on our standard warranty. Bearings will be selected to meet specified life but will carry the same warranty as the rest of the motor.
7. 175% EHT is available only on frame sizes 324 through 8011, open and enclosed. Add 4% to the list price.
8. 300% EHT is available only on frame sizes 444 through 9608 with, WPI, WP11 enclosures and 449 through 6812 frame sizes with TEFC enclosures. Not available on 5008 Hazardous Location. Add 7.5% to the base list price. (On 2 pole requirements, refer to the Inquiry Group.)
Any requirements above 300% must be referred to the Inquiry Group. Add 10% for 500% EHT if approved.
9. Water cooling coils for thrust bearing oil sumps are available on 324 through 9608, WPI and WP11 frames as well as 449 through 6812 TEFC frames. 300% EHT (and above) antifriction bearing arrangements may require water cooling coils in the oil bath. Plate type bearing arrangements always require this feature. Both of these bearing configurations are designed to handle very high pump thrust loads. Because these configurations generate tremendous heat buildup in the oil bath, water cooling coils help dissipate the heat and maintain oil viscosity.
 - Nidec Motor Corporation's standard water cooling coils are designed from copper construction to be self draining and require a minimum of 4 GPM at a maximum of 125 PSI with an inlet temperature of 90° F or less.
 - When a customer requires water cooling coils and they are not standard, add 5% to the list price for copper cooling coils, add 7.5% for stainless steel cooling coils.



MODIFIABLE PRICING INSTRUCTIONS



6. BEARINGS (continued)

B. BEARING LIFE

10. Oil-lubricated lower (guide) bearings are provided as standard on high-thrust WPI and WP11 motors with 5813 through 9608 frames sizes and on high-thrust TEFC motors with 5008 through 6812 frame sizes.

Oil-lubricated lower bearings are available as an option on high-thrust 4-Pole and slower WPI and WP11 motors with 5008 through 5012 frame sizes. When required, add \$1,913 to the list price. Note that VHS BX dimension is limited to 2.50" when providing this feature.

11. Gate valves and extended oil drains. Motors with oil-lubricated bearings are supplied with suitable provisions for draining the oil sumps. In some cases, the customer may require a pipe extension and a gate valve to allow for more convenient oil changes. The typical extension length is four inches. To include this feature when oil-lubricated bearings are standard, add to the list price as follows:

Upper sump per motor, add \$880 list adder:

high-thrust WPI and WP11 447 through 5012 frame
 high-thrust TEFC motors 447 through 449 frame

Upper and lower sumps per motor, add \$1,761 list adder:

high-thrust WPI and WP11 6808 through 9608 frame
 high-thrust TEFC motors 5008 through 6812 frame

12. An insulated thrust bearing to prevent circulating shaft currents is a standard feature on all motors in the 5008 through 9608 frame series.

Should a customer require an insulated bearing on a smaller frame or on both bearings for a 180 frame or larger, make the appropriate list price adder shown below.

Insulated Bearing (Upper Bearing)

Frame:	182	213	254	284	324	364	404	444	449	5000	5800	6812 (TE)	6800-8000	9600
	184	215	256	286	326	365	405	447						
Adder:	\$550	\$850	\$1,200	\$1,500	\$1,500	\$1,500	\$1,500	\$1,500	\$1,800	\$0	\$0	\$0	\$0	\$0

Insulated Bearing (Both Bearings)

Frame:	182	213	254	284	324	364	404	444	449	5000	5800	6812 (TE)	6800-8000	9600
	184	215	256	286	326	365	405	447						
Adder:	\$1,100	\$1,700	\$2,400	\$3,000	\$3,000	\$3,000	\$3,000	\$3,000	\$3,600	\$2,400	\$2,400	\$3,000	\$3,000	\$3,000

13. PLATE TYPE THRUST BEARINGS.

- Available only on 9600 frame sizes - solid shaft motors only
- Actual worst case (shut-off) thrust values must be known to properly quote this option
- This option may extend delivery
- Full-load test not available

Plate-type bearings offer the highest thrust carrying capacity of all configurations offered by Nidec Motor Corporation. Unlike rolling element bearings, these operate on an oil film and have little, if any, overload capacity. Overload will quickly result in failure. This arrangement also has the greatest impact on motor efficiency due to its high losses. The engineer or user concerned with product performance should be apprised of this. When properly applied and maintained, this bearing has an infinite theoretical life and is always supplied with water cooling coils. Inherent to its design, this option requires an auxiliary bearing system to handle upthrust and radial loads. Refer to marketing for price and availability.



† All marks shown within this document are properties of their respective owners.

MODIFIABLE PRICING INSTRUCTIONS

**BUSS BAR
CONDUIT BOX**

7. BUSS BAR CONNECTIONS

For three insulated standoffs with buss-bar terminations for incoming supply cables, add \$4,178 to the list price. Available in 449 frame sizes and larger only. Double adder for 2 speed/2 winding motors. Does not imply a phase segregated arrangement.

8. CONDUIT BOX ARRANGEMENTS

A. NEMA^{®†} FRAME (182-447)

Standard product is supplied with a single main conduit box that can be rotated in 90° steps to position the single entrance hole according to the power feeder cable. The typical "A-A" dimension to accommodate feeder cables for the 182-215 frame is 1.0 inches, the 254-256 frame is 1.25 inches, the 284-286 frame is 1.5 inches, and the 324-447 frame is 3.0 inches. Refer to dimension prints for your specific product. Standard box is a NEMA 3 enclosure.

- The standard conduit box material for aluminum-frame WPI and TEFC motors in the 182-286 frame is aluminum or steel
- The standard conduit box materials for cast-iron frame WPI and TEFC motors in the 324-447 frame size is steel or cast iron
- CORRO-DUTY[®] TEFC and all hazardous location motors are supplied with a cast-iron conduit box

Typical descriptions for NEMA^{®†} Verticals*

Motor Type	Box Use	Ref. Note	Box Matl	Nidec Motor Corporation Vol.	A-A Dim	THD Hub	Internal Casting Dimensions			Bolt Pattn (SQ)
							H	W	D	
FRAME SIZE 182-184										
TEFC	STD		AL	60	1.0	NO	3.6	5.7	2.9	A
CDUTY	STD	(4)	CI	36	1.0	YES	3.8	4.1	2.3	2.125
XP	STD		CI	36	1.0	YES	3.8	4.1	2.3	2.125
FRAME SIZE 213-215										
WPI	STD		AL	60	1.0	NO	3.6	5.7	2.9	A
TEFC	STD		AL	60	1.0	NO	3.6	5.7	2.9	A
CDUTY	STD	(4)	CI	36	1.0	YES	3.8	4.1	2.3	2.125
XP	STD		CI	36	1.0	YES	3.8	4.1	2.3	2.125
FRAME SIZE 254-256										
WPI	STD		AL	66	1.25	NO	4.5	3.9	3.8	A
TEFC	STD		AL	90	1.25	NO	4.0	6.6	3.4	A
CDUTY	STD	(4)	CI	60	1.5	YES	4.37	4.37	3.1	2.5
XP	STD		CI	60	1.5	YES	4.37	4.37	3.1	2.5
FRAME SIZE 284-286										
WPI	STD	(1)	AL	100	1.5	NO	4.6	4.6	4.7	2.5
TEFC	STD	(1)	AL	137	1.5	NO	4.9	8.4	3.3	2.5
CDUTY	STD	(1)	CI	186	2.0	YES	7.0	5.8	4.6	2.5
XP	STD	(1)	CI	186	2.0	YES	7.0	5.8	4.6	2.5



† All marks shown within this document are properties of their respective owners.

MODIFIABLE PRICING INSTRUCTIONS

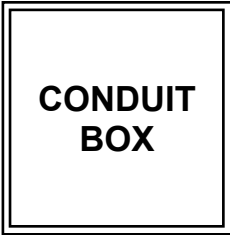

8. CONDUIT BOX ARRANGEMENTS (continued)

A. NEMA^{®†} FRAME (182-447)

Motor Type	Box Use	Ref. Note	Box Matl	Nidec Motor Corporation Vol.	A-A Dim	THD Hub	Internal Casting Dimensions			Bolt Pattn (SQ)
							H	W	D	
FRAME SIZE 324-326										
WPI	STD		STL	347	3.0	NO	8.0	6.5	6.88	4.0
WPI	OPT	(1)	CI	330	3.0	YES	8.5	7.25	6.88	4.0
TEFC	STD		STL	195	2.0	NO	6.75	5.5	5.38	2.5
TEFC	OPT	(2)	CI	194	2.0	YES	7.0	6.5	5.125	2.5
XP	STD		CI	194	2.0	YES	7.0	6.5	5.125	2.5
FRAME SIZE 364-365 404-405										
WPI	STD		STL	347	3.0	NO	8.0	6.5	6.88	4.0
WPI	OPT	(1)	CI	330	3.0	YES	8.5	7.25	6.88	4.0
TEFC	STD		STL	347	3.0	NO	8.0	6.5	6.88	4.0
TEFC	OPT	(1)	CI	330	3.0	YES	8.5	7.25	6.88	4.0
XP	STD		CI	542	3.0	YES	9.0	10.75	7.63	4.0
FRAME SIZE 444-445 **										
WPI	STD		STL	563	3.0	NO	9.5	7.75	7.75	5.0
WPI	OPT	(3)	CI	525	3.5	YES	9.5	9.0	6.0	5.0
TEFC	STD		STL	563	3.0	NO	9.5	7.75	7.75	5.0
TEFC	OPT	(3)	CI	525	3.5	YES	9.5	9.0	6.0	5.0
XP	STD		CI	542	3.0	YES	9.0	10.75	7.63	5.0
FRAME SIZE 447										
WPI	STD		CI	2000	3.5	YES	16.25	16.0	10.25	5.0
TEFC	STD		STL	563	3.0	NO	9.95	7.75	7.75	5.0
TEFC	OPT		CI	525	3.5	YES	9.95	9.0	6.0	5.0
XP	STD		CI	542	3.0	YES	9.0	10.75	7.63	5.0

*Subject to change due to NEMA or NEC requirements and/or Nidec Motor Corporation good engineering practices.

** 250 HP - 1300 cubic inch cast box.

NOTES: Cast-iron conversion kits for stock motors are (1) P/N 888949, (2) P/N 888948, (3) P/N 888940 (4) Modified may deviate larger (A) Bolt pattern is 2.375 x 1.875, STD=Standard, OPT=Optional, STL= Steel, AL=Aluminum, CI=Cast Iron, THD HUB= Threaded Hub. Volume is in cubic inches.

NEMA 4X EPOXY COATED CONDUIT BOX

FRAME SIZE	182	213	254	284	324	364	404	444	447
	184	215	256	286	326	365	405	445	
LIST ADDER	\$352	\$469	\$587	\$704	\$822	\$939	\$1,056	\$1,174	\$1,174

*All conduit boxes will be painted internally and externally with an epoxy paint that meets the requirements of UL 1332 for NEMA 4X enclosure per NEMA 250



MODIFIABLE PRICING INSTRUCTIONS

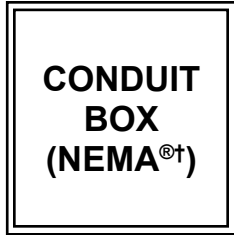

8. CONDUIT BOX ARRANGEMENTS (continued)

A. NEMA®† FRAME (182-447)

1. To provide a standard size cast-iron conduit box with a single 3.0 inch diameter threaded hub (A-A dimension), add the list adder shown below:

FRAME SIZE	324 326	364 365	404 405	444 447
LIST ADDER	\$293	\$469	\$587	\$704

For 324-447 frame WPI and TEFC motors only.

2. Special oversized cast iron conduit box selections for NEMA frame (400-440) motors are as follows:

LIST PRICE ADDITIONS NEMA®† - TITAN® CROSSOVER OPTIONS

Titan Size	Frame ⁽¹⁾	List	Material	Vol In ³	Qty Hubs
1.0	400	\$1,056	Cast Iron ⁽²⁾	900	1-3.5"
1.0	440	\$939			
1.5	400	\$3,052	Cast Iron ⁽²⁾	3200	2-3.5"
1.5	440	\$2,817			
2.0	400	\$1,526	Cast Iron	1300	1-3.5"
2.0	440	\$1,408			
2.5	400	\$2,817	Cast Iron	2000	1-3.5"
2.5	440	\$2,580			
3.0	400	\$3,580	Cast Iron	3400	2-3.5"
3.0	440	\$3,343			

Notes: (1) 400 frame requires an adapter plate that will increase NEMA AB and AC dimensions
 (2) Hazardous location motors only

3. Ground -- For a ground lug (GL) inside of the conduit box, add \$108 to the list price. (Standard on CORRO-DUTY®, severe duty, and hazardous location options).
4. Oversize -- For a steel conduit box one size larger than standard, add \$178 list for 180-400 frames. Add \$704 list for 440 frame. Does not apply to TITAN® motors. (Not available with item 2)
5. For double gasketed or NEMA®† 4 protection, add \$178 to the list price. (Standard on CORRO-DUTY® and severe-duty options)
6. For an accessory conduit box (324-447 frames only) to terminate the leads of internal accessories such as space heaters, thermostats, etc., in a separate dedicated conduit box, add \$901 to the list price.
7. For an oversized accessory conduit box (320-447 frames only) with terminal strip connectors and the capability to terminate up to two external accessories (vibration detector, bearing RTD, etc.), add \$1803 to the list price. To prewire external accessories to this box, add \$188 each to the price list.
8. For prewire of vibration detectors to accessory conduit box, add \$376 each to the list price



† All marks shown within this document are properties of their respective owners.

MODIFIABLE PRICING INSTRUCTIONS

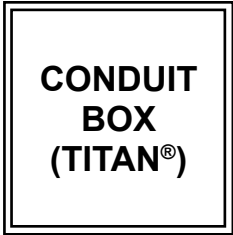

8. CONDUIT BOX ARRANGEMENTS (continued)

B. TITAN® FRAME (449-9600)

The standard product is supplied with a large, single, main conduit box of cast iron or fabricated steel as shown in the table on page P-102. It typically has one usable 3-1/2 inch diameter threaded conduit hub (A-A dimension). If specified at order entry, Nidec Motor Corporation will provide up to three threaded hubs that are up to 4.0 inches in diameter available on size 3.5, 4.5, 6 or 8 boxes. Most options can be rotated in 4 steps of 90° to accept top, bottom or side feeder cable positions. When physical size will not allow the box to be rotated (size 3.5, 4.5, 6, 8), specify desired location of the hub(s). If not specified, the size and location will be as shown on the following pages. All conduit boxes meet NEMA Type 4 enclosure requirements.

Standard conduit box assignments and available options are illustrated in the table on the following page. Certain accessories require an oversized main conduit box. The cost of this feature is not included in the accessory price unless otherwise stated. To interpret which conduit box is required to accommodate the desired features, refer to the index below before selecting the appropriate conduit box from the assignment table.

SELECTION INDEX

- A-OPTION Oversized terminal box for extra or larger leads or stress cones
- B-OPTION Accommodates stress cones with one of the following: lightning arrestors, surge capacitors, current transformer, or buss connection
- C-OPTION Accommodates stress cones with any two of the following: lightning arrestors, surge capacitors, current transformer, or buss connection
- D-OPTION Terminal box accommodates all components: stress cones, lightning arrestors, surge capacitors, current transformer, and buss connection

Note: Stress cones are not an Nidec Motor Corporation-supplied accessory but rather a method of connecting motor leads to shielded feeder cables often selected by the customer. Stress cones typically require an oversize box to simply make this connection.

NEMA 4 X CONDUIT BOXES

NEMA 4X EPOXY COATED CONDUIT BOX Stainless-Steel

Selection Chart	Vertical NEMA 4X (S.S.) Adder
BTD Condulet	\$2,250 per BTD
Acc. C/B**	\$4,155 per Box
Size 2.5	\$8,070
Size 3	\$10,445
Size 3.5	\$12,030
Size 4.5	\$14,905
Size 5	\$20,100
Size 6	\$24,120
Size 8	\$28,945

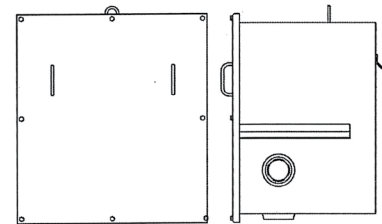

*All boxes will be externally coated with same paint as motor
**Includes Terminal Board

EPOXY PAINT COATED

Selection Chart	Vertical NEMA 4X (Epoxy Painted) Adder
All Conduit Box*	\$1,878

*All conduit boxes will be painted internally and externally with an epoxy paint that meets the requirements of UL 1332 for NEMA 4X enclosures per NEMA 250



MODIFIABLE PRICING INSTRUCTIONS

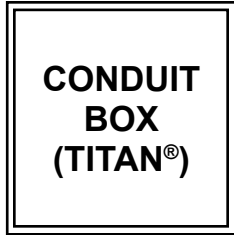

8. CONDUIT BOX ARRANGEMENTS (continued) B. TITAN® FRAME (449-9600)

MAIN CONDUIT BOX SELECTION TABLE

Enclosure	Frame	Voltage	Horsepower	Conduit Box Options					
				STD	A	B	C	D	
Div. 1 Hazardous Location	5000	460 & 2300	ALL	1	1.5	N/A	N/A	N/A	
	5800	4000	ALL	1.5	1.5	N/A	N/A	N/A	
TEFC	449 5000 5807 5809 5811	460	UP TO 500	2	3	4.5	5	6	
			501 & UP	3	4.5	4.5	5	6	
		2300	ALL	2	3	4.5	5	6	
		4000	ALL	2.5	3	4.5	5	6	
		6600	ALL	3.5	4.5	8	8	8	
	5812	460	ALL		3	3	4.5	5	6
					3	3	4.5	5	6
		2300	ALL	3	3	4.5	5	6	
		4000	ALL	3	3	4.5	5	6	
		6000	ALL	3.5	4.5	6	8	8	
	6812	460	ALL	4.5	4.5	4.5	5	6	
		2300	ALL	4.5	4.5	4.5	5	6	
		4000	ALL	4.5	4.5	4.5	5	6	
		6000	ALL	4.5	4.5	6	8	8	
	WPI WP II	449 5000 5800	460	UP TO 499	2.5	3	4.5	5	6
500 & UP				3	3	4.5	5	6	
2300			ALL	3	3	4.5	5	6	
4000			ALL	3	3	4.5	5	6	
6000			ALL	3.5	4.5	6	8	8	
6800 8000 9600		2300	ALL	3	4.5	4.5	5	6	
		4000	UP TO 1000	3	4.5	4.5	5	6	
			1001 & UP	4.5	4.5	4.5	5	6	
		6000	ALL	3.5	4.5	6	8	8	

Motors rated 3300 Volt will follow same guidelines as 4000 Volt shown in the table above.
Motors rated for voltages above 4800 Volt will use a Size 3.5 box as standard.
Size 8 box is only available on motors with voltages above 5000 Volt.

LIST PRICES FOR OPTIONAL MOTOR MOUNTED MAIN CONDUIT BOXES

SIZE	LIST ADDER	MATERIAL	VOLUME IN ³
1.5	\$3,521	C.I.	3200
2.5	\$3,228	C.I.	2000
3	\$4,178	C.I.	3400
3.5	\$4,812	F.S.	5700
4.5	\$5,962	F.S.	16200
5	\$8,040	F.S.	28000
6	\$9,648	F.S.	40400
8	\$11,578	F.S.	48200

CI = CAST IRON F.S. FABRICATED STEEL

Reference drawings for conduit box selection are shown on the following page with standard location of threaded hubs as indicated.



† All marks shown within this document are properties of their respective owners.

MODIFIABLE PRICING INSTRUCTIONS

CONDUIT
BOX
(TITAN®)

8. CONDUIT BOX ARRANGEMENTS (continued) B. TITAN® FRAME (449-9600)

REFERENCE DRAWINGS

TYPICAL PROFILE FOR
SIZES 1, 1.5, 2, 2.5, AND 3

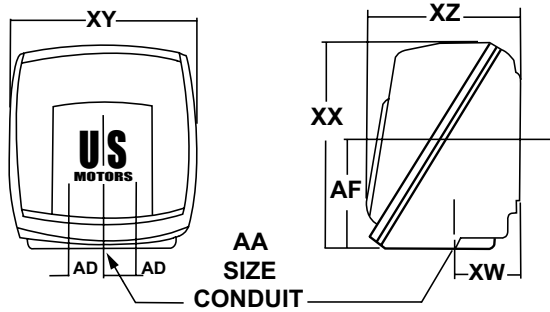

Dimensions may vary up to 1/4" due to casting or fabrication variations.

TYPICAL PROFILE FOR
SIZES 3.5, 4.5, AND 6

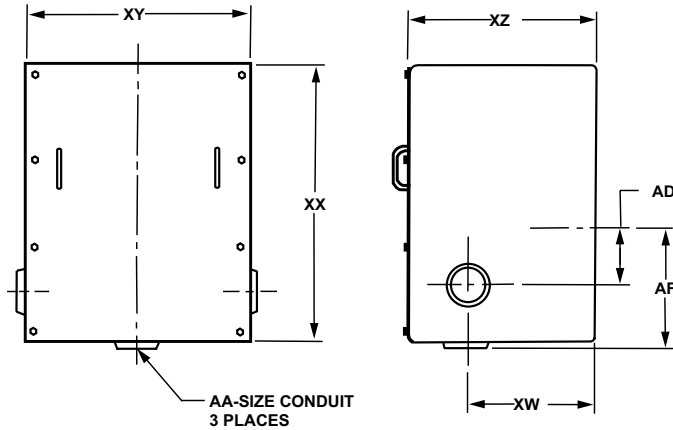

MODIFIABLE PRICING INSTRUCTIONS

**CONDUIT
BOX
(TITAN®)**

8. CONDUIT BOX ARRANGEMENTS (continued)

B. TITAN® FRAME (449-9600)

TITAN® CONDUIT BOX REFERENCE DIMENSIONS

BOX SIZE	QTY HUBS	AF	AD	XW	EXTERIOR			INTERIOR			CONST. MAT'L	USABLE VOLUME
					XX (H)	XY (W)	XZ (D)	XX (H)	XY (W)	XZ (D)		
1	1	5-5/8	---	3-15/16	14	14	10-5/8	11-3/8	12	9-1/2	C.I	900
1.5	2	8-5/8	3	6-1/8	19	18	16-1/2	17-1/2	15	15	C.I	3200
2	1	8-1/16	---	5	15	14	10-1/2	13-1/2	11-1/2	9-1/2	C.I	1300
2.5*	1	10	---	6	17-3/4	18	11-1/2	16	15	10	C.I.	2000
3	2	10-15/16	3	8-1/8	19	19-3/8	17-5/32	16-1/8	15-3/8	13-5/8	C.I.	3400
3.5	3	10-13/16	4	8	24	18	14	23-3/4	17-3/4	13-5/8	F.S.	5700
4.5	3	17-13/16	11	14	30	28	20-1/8	29-1/2	27-3/4	19-3/4	F.S.	16200
5	3	19-13/16	13	14	40	36	20	39-3/4	35-3/4	19-5/8	F.S.	28000
6	3	19-13/16	13	24-1/2	40	32	29	39-3/4	35-3/4	28-5/8	F.S.	40400
8	3	19-13/16	13	24-1/2	48	32	29	47-1/2	35-1/2	28-5/8	F.S.	48200

NOTES: C.I. = CAST IRON, F.S. = FABRICATED STEEL

*WPI/WPII 449 frame up to 450HP has a size 2.5 box with Qty. 2 hubs.

TITAN® Conduit Box Options & Accessories

- For a ground lug or servit post mounted in the conduit box, add \$164 to the list price.
- For a single accessory conduit box used to terminate the leads of internal devices (space heaters, thermostats, etc.) to a dedicated location, add \$1,127 to the list price. (Accessory box is shown on dimension prints.)
- A second accessory conduit box can be provided in addition to item 2. For two separate accessory conduit boxes, add \$2,254 to the list price. Note: Second accessory box is not available on 5008 Frame Hazardous Location motors.
- For a single oversized accessory conduit box with terminal strip connectors and the capability to terminate up to three external accessories (bearing RTDs, vibration detectors, etc.), add \$2,254 to the list price. To prewire external accessories to this box, add \$235 to the list price.
- An accessory conduit box supplied with winding RTDs or thermocouple includes leads prewired to a terminal strip for ease of customer connection at no charge. To add terminal strip connection when RTDs are not included, add \$258 to the list price.
- NEMA Type I conduit box (terminal housing). Nidec Motor Corporation's standard conduit box meets or exceeds the volume requirements of a NEMA Type I (Table 20-3) conduit box. Cover-to-box and box-to-frame are gasketed.
- NEMA Type II conduit box. To modify a standard main conduit box arrangement to NEMA Type II volume requirements, along with standoff insulators with copper buss bar lead connectors and a ground lug, add as follows:

FRAME	MOTOR VOLTAGE		
	460/600	2300/4800	6000/6900
449/5000	\$5,500	\$6,876	---
5800	\$5,500	\$6,876	\$13,352
6812 (TE)	\$5,500	\$6,876	\$13,352
6800	---	\$6,876	\$13,352
8000	---	\$6,876	\$13,352
9600	---	\$6,876	\$13,352

*Refer to Inquiry Group for availability on 6600/6900 volts.



† All marks shown within this document are properties of their respective owners.

MODIFIABLE PRICING INSTRUCTIONS

CONDUIT
BOX
COUPLINGS

8. CONDUIT BOX ARRANGEMENTS (continued)

B. TITAN® FRAME (449-9600)

8. For a space heater installed in a size 4.5 , 6 or 8 main conduit box, add \$2,864 to the list price. This includes a conduit box termination off main box with 3/4" A-A.
9. For a lead positioning gasket, add \$223 to the list price.
10. To provide a hinged front cover to a size 4.5 , 6 or 8 conduit box, add \$1,016 to the list price. To include a key lock (2 keys), add \$516 to the list price.
11. Buss bar terminal connection -- to add three standoff insulators to size 4.5 , 6 or 8 conduit boxes, add \$4,178 to the list price. For two-speed, two-winding motors, double adder. Requires size 4.5 or larger conduit box adder.
12. Phase segregated conduit box arrangements are not available.

Caution: This accessory is not intended for use on hazardous location motors without approval of the Inquiry Group and the addition of a special oversized hazardous location conduit box. When approved, add \$39,366 LIST FOR ONLY THE CONDUIT BOX UPGRADE REQUIRED FOR HAZARDOUS LOCATION MOTORS. This option will extend delivery. This option is only available on motors with a maximum full-load current of 600 AMPS, 449 frame and larger.

The quick-disconnect/separable connector offering includes the apparatus bushing and connector kit. When ordering this option, the following information must be supplied:

- a) Number of power feeder cable per phase
- b) Cable size
- c) Cable construction -- solid or stranded
- d) Type of cable shielding
- e) Diameter of the cable insulation (not the cable jacket)

To include this accessory with frame sizes of 449TP and larger, add \$11,197 to the list price, which includes an oversized conduit box and three connectors. For motors with multiple leads per phase, add \$7,824 to the list price for each additional set of three connectors. If other accessories will be mounted in the main conduit box, make the appropriate accessory and conduit box adders.

9. COUPLINGS

A. HOLLOSHAFT® MOTORS

All vertical HOLLOSHAFT® motors described in this catalog include a specialized drive coupling mounted at the top of the motor. The coupling bore diameter (BX dimension) must be closely matched to the diameter of the pump head-shaft. Each frame series has a variety of BX dimensions available. These can be found in the dimension print section on page E-3-E-5. Customers who do not order a nonreverse ratchet can select from two methods of fastening the drive coupling to the motor.

- Pinned drive couplings are used to prevent the pump line shaft from completely unscrewing in the event of a power failure or phase reversal. Should the pump spin fast enough in reverse to begin to unscrew the shafting, the drive coupling will lift up off its pins and spin with the pump shaft. This is known as a self-release coupling (SRC).
- Bolted drive couplings are used when the upthrust conditions exist. This method prevents the drive coupling from becoming disengaged from the motor (lifting off its pins) during upthrust. The bolted coupling arrangement offers no reverse rotation protection. If this is required, the customer should order a nonreverse ratchet (NRR) described in item 25 on page M-39.



† All marks shown within this document are properties of their respective owners.

MODIFIABLE PRICING INSTRUCTIONS

COUPLINGS
CURRENT

9. COUPLINGS (continued)

B. SOLID SHAFT MOTORS

Nidec Motor Corporation does not supply a coupling on this product; the customer must furnish their own coupling.

10. CURRENT TRANSFORMERS FOR DIFFERENTIAL PROTECTION

A healthy motor maintains the same magnitude of current flowing in and out of each phase of its winding. A breakdown in the insulation system alters this balance, resulting in a measurable difference when the current flowing in and out of each circuit is compared for symmetry. Any dissimilarity within an individual circuit is known as differential current and can be detected with current transformers that provide differential protection.

Differential protection is accomplished by bringing out both ends of the winding into the main motor conduit box. Both leads of each circuit pass through the center of a dedicated window-type current transformer. In a self-balancing system, the 3 CTs are located at the motor. When a fault is detected, a signal is sent to a relay (not provided by Nidec Motor Corporation) in the switchgear, taking the motor offline.

An alternate system includes 3 additional CTs in the switchgear and is commonly known as a conventional system. In most cases, the switchgear OEM provides all 6 CTs since their characteristics must be closely matched for maximum protection.

The conventional system provides a greater zone of protection (motor and cable run). However, it is significantly more expensive and less sensitive than the self-balancing method since it requires a higher fault current to trip the relay.

A. PRICING OF CURRENT TRANSFORMERS

- Available on frame sizes 449 through 9608
- For 2 winding multispeed motors, double list price adder

WINDOW TYPE CTs -- For a quantity of 3 window-type (typically type IMC 50:5 ratio) current transformers supplied and mounted by Nidec Motor Corporation, add as follows:

460 - 4800 volts \$8,554 list
5000-6900 volts \$11,103 list

MOUNTING ONLY -- Nidec Motor Corporation will mount customer-supplied current transformers for \$2,331 list each. This requires a complete description and a dimension print of supplied accessory.

- Do not apply to hazardous location motors without mandatory Inquiry Group approval*
- Required oversize main conduit box **is not included** in these list-price adders

**Hazardous location use requires a special oversized main conduit box and mandatory approval by the Inquiry Group. When approved, the price for this special conduit box only is \$37,089 list.*

