

TITAN® 449 Frame

WP11 Vertical A.C. Motors



Product Specifications

Horsepower: 150-450 HP

Speed Range: 900 – 1800 RPM

Design Voltages: 460 through 4000
Voltage 50 or 60Hz

Enclosure: Weather Protected II

Efficiency Level: Standard, Energy and
Premium

Product Overview

Nidec Motor Corporation is continually improving the TITAN motor line to meet customer needs for performance, efficiency, and reliability and is pleased to announce a new Weather Protected II (WP11) enclosure offering on its vertical 449 frame platform.

WP11 enclosures are excellent choices for indoor or outdoor use, typically have lower initial costs, are more efficient than totally enclosed motors, and are typically only available on larger frame sized motors.

The 449 motors are designed with a stiff construction to effortlessly attach to the pump head, to raise reed critical frequency (RCF) on average 12%, and to allow altering the RCF for the best variable speed pumping system setup to stay out of the resonance region by offering multiple p-base options.

Product Overview and Options

- Solid Shaft or HOLLOSHAFT®
- 1.15 service factor
- Class F insulation
- Class B rise at full load (sine wave power up to 450HP)
- Thrust capacities among highest in industry
- Non-Reverse Ratchet, BALLOMATIC®
- LUBRIPORT® oil sight level window
- Corrosion-resistant paint capable of withstanding a 500-hour salt spray test
- Copper windings; aluminum rotors
- Cast iron frame construction and cast iron end brackets
- Zinc plated hardware

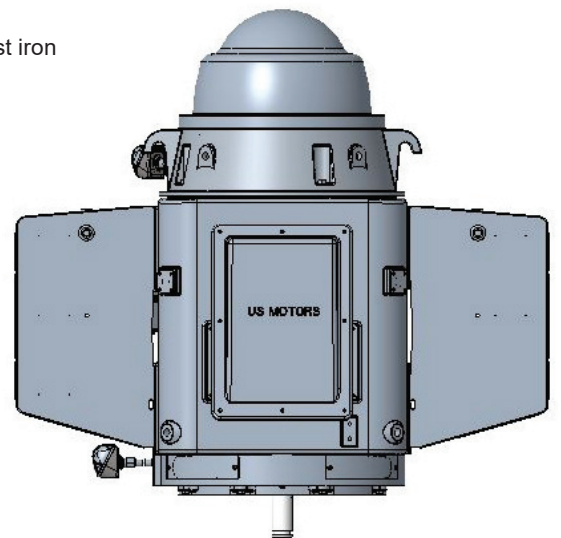

Custom Design Options

- Design for high altitude and high or low ambient temperatures
- Copper bar rotor
- EVERSEAL^{®†} insulation system
- Extra high thrust tandem or spherical roller bearings
- Oil sump heater
- Winding thermal protection options include 100 ohm, 120 ohm or 10 ohm RTDs, thermostats, thermocouples and thermistors
- Inverter Duty to meet NEMA^{®†} MG1, Part 31
- Shaft ground ring or brush
- Special balance
- Stainless steel hardware
- Vibration transmitters
- API^{®†} 610 tolerances
- Sound abatement

Conduit Box Options

- Oversized main conduit box
- Grounding lug in main conduit box
- Lead positioning gasket
- Surge capacitors, lightning arrestors, and current transformers
- NEMA^{®†} Type II conduit box with standoff insulators and copper buss bar lead connectors
- NEMA^{®†} 4X conduit box

Testing

Nidec Motor Corporation conducts a short commercial test on each TITAN^{®†} WPII motor consisting of no load current tests, locked rotor current (performed at reduced voltage), winding resistance, high potential and a vibration check.

Optional Tests

- Un-witnessed or witnessed short commercial test
- Witnessed or un-witnessed versions of the following tests are available:
 - Polarization index
 - Sound test
 - Sealed winding conformance test
- Complete initial test consisting of a full load heat run and test of percent clip, calibration test, full load current, locked rotor torque, breakdown torque (calculated), efficiency, power factor at 100%, 75% and 50% of full load, short circuit, and megger.
- Special test to customer requirements

Warranty

WPII TITAN^{®†} motors carry the following warranties:

- Standard (Energy) efficient – 12 months from date of installation, maximum 18 months from manufacturing date
 - Premium efficient – 24 months from date of installation, maximum 30 months from manufacturing date
 - Inverter Duty - 24 months from date of installation, maximum 30 months from manufacturing date
- U.S. MOTORS^{®†} brand WPII TITAN^{®†} products are manufactured in our ISO 9001 certified Mena, Arkansas facility.

For additional information, please refer to our Modified Vertical Motors Catalog (PB500) or contact your Nidec Motor Corporation representative

† All marks shown within this document are properties of their respective owners.

Nidec Motor Corporation, © 2020; All Rights Reserved. U.S. MOTORS[®] is a registered trademark of Nidec Motor Corporation. Nidec Motor Corporation trademarks followed by the ® symbol are registered with the U.S. Patent and Trademark Office.