

Instruction Manual

Installation
Operation
Maintenance

KAMAG Voltage Regulators

Publication
351-01021-00 (May 1980)



PUBLICATION NUMBER: 351-01021-00
PUBLICATION DATE: MAY 1980
SUPERSEDES PUBLICATION INSR-3-68E

TABLE OF CONTENTS

SECTION 1 INTRODUCTION & THEORY OF OPERATION

INTRODUCTION	1
THEORY OF OPERATION	1

SECTION 2 INSTALLATION & OPERATION

INSTALLATION	6
VOLTAGE ADJUSTMENT	6
STABILITY ADJUST	6
ENGINE IDLE SWITCH	6

SECTION 3 TROUBLESHOOTING

TROUBLESHOOTING CHART	7
---------------------------------	---

SECTION 4 PREVENTIVE MAINTENANCE

PERIODIC INSPECTION AND CLEANING	9
ORDERING REPLACEMENT PARTS	9

SECTION 5 COMPONENTS TEST PROCEDURES

RECTIFIER TEST	9
CAPACITOR TEST	9
SATURABLE TRANSFORMER	10
POWER TRANSFORMER TEST	10
CURRENT TRANSFORMER TEST	10
POTENTIOMETERS AND RESISTORS	10
SILICON TRANSISTOR TEST	10
TRANSISTOR TEST CHART	11
ZENER DIODE TEST	11
REGULATOR VOLTAGE AND RESISTANCE MEASUREMENTS	12
RESISTANCE AND VOLTAGE MEASUREMENTS CHART	12

ILLUSTRATIONS

KAMAG VOLTAGE REGULATOR (top view)	1
Figure 1 Closed Loop Control Diagram, Generator & Voltage Regulator System	2
Figure 2 Magnetic Amplifier	2
Figure 3 Error Detector	3
Figure 4 Amplifiers Q1, Q2	3
Figure 5 Schematic Wiring Diagram for KATO KAMAG Voltage Regulator	3
Figure 6 Electrical Schematic, KATO KAMAG Voltage Regulator with Optional Paralleling Accessories	4
Figure 7 Schematic Wiring Diagram for KAMAG Printed Circuit Board Voltage Regulator Preamplifier 841-02052-00	5
Figure 8 Voltage Regulator (side view)	6
Figure 9 Silicon Rectifier	10
Figure 10 Three Volt Test Light	10
Figure 11 Silicon Transistors	11
Figure 12 Zener Diode Test	11

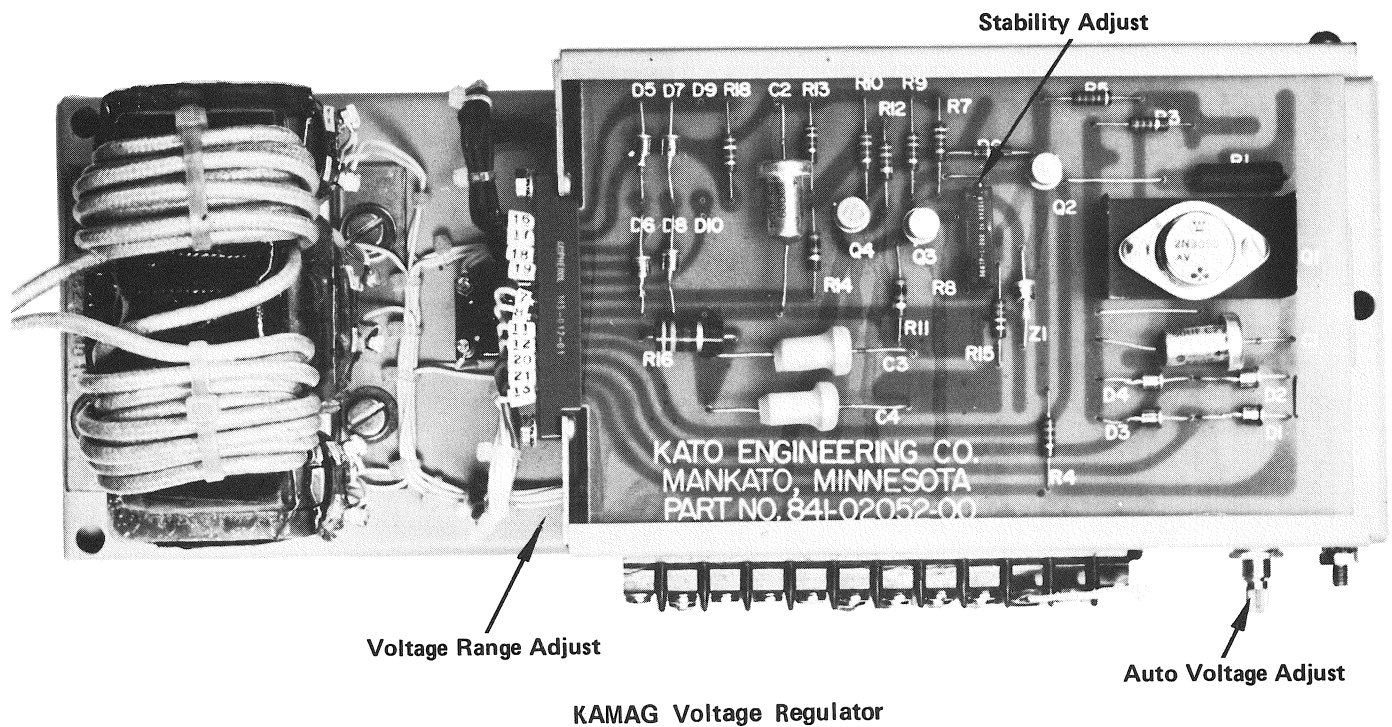

SECTION 1 DESCRIPTION & THEORY OF OPERATION

INTRODUCTION

Field proven KATO KAMAG Voltage Regulators are used on the KATO KAMAG 14 and 18 Alternating Current Generators. The KAMAG Voltage Regulator consists of a solid state preamplifier and a magnetic amplifier. Design of the voltage regulator is such that it can be used equally well on single or three phase, 50 or 60 cycle systems. The standard line of KATO KAMAG Voltage Regulators provide plus or minus 2% regulation.

The regulators incorporate voltage RMS sensing and current boost. The current boost feature, not normally found on voltage regulators of comparable cost, provides short circuit current boost which ensures excellent motor starting characteristics. An adjustable current feedback circuit ensures optimum transient response to load changes. The voltage regulator causes no distortion of generator waveshape.

The KAMAG Voltage Regulator (figure 5 or 6) is designed to provide a maximum continuous output current of 1.75 amperes at 50 degrees Centigrade ambient. The regulator will provide forcing current of 2.25 amperes at 50 degrees Centigrade for 2 minutes. Maximum DC Voltage is limited, by regulator design, to prevent excessive field forcing. The Voltage Regulator voltage power is 120 volt AC plus or minus 10%.

THEORY OF OPERATION

The closed loop control diagram (figure 1) shows the generator regulator system divided into basic function blocks. The generator provides a means of converting mechanical energy from a motor or engine to electrical energy. To increase the generator ability to perform as an infinite bus a voltage regulator is used as a generator field exciter. With external constant field excitation the generator terminal voltage would be the inherent regulation, ranging from 10% to 50%. A regulator of the KAMAG series will improve regulation to plus or minus 2% or better under rated full load conditions. The regulator obtains its power from the generator output voltage and current.

SATURABLE TRANSFORMER

Voltage and current are combined magnetically in a saturable transformer, see figure 2 and (TS1) figure 5 and 6. The saturable transformer is designed with a control winding (C1, C2) to vary the output as an inverse proportional power amplifier, that is, increasing control signal results in reduced output. The saturable transformer requires about 300 ampere turns for control over a 10 to 1 range.

Winding (H) provides the power to TS1. Power is obtained from the generator output. Linear reactor (L1) is a series,

current limiting reactor which provides for reasonable constant supply current to (TS1) under no load conditions.

Current Boost winding (I) is the load current boost. Since generator field excitation is nearly proportional to load current, an increasing load will provide additional current to TS1 resulting in nearly the exact increase in field excitation.

Control winding (C) provides a means for voltage adjustment and compensation for circuit tolerance and increases in field power due to thermal effects.

Winding (X) is the output AC which is rectified by a full wave diode bridge (BR-1). The DC output of the rectifier bridge provides field excitation.

PREAMPLIFIER

Output of the preamplifier, figure 7, provides DC control current to the control windings on Saturable Transformer (TS1). As stated previously, an increase in control current results in a decrease in regulator output.

Stepped down sensing voltage from transformers T1, T2 is applied to a full wave rectifier bridge D5 through D10, rectified and filtered by capacitor C2, resistor R18 and choke L2 and applied across a voltage divider.

The voltage divider consists of resistors R13, R14, R12 mounted on the printed circuit board and Voltage Adjust R18 and Voltage Range Adjust R19 mounted on the regulator chassis. A portion of this voltage, sampled at the junction of R13 and R14, is applied as input to one side of an error detector.

The error detector and amplifier consists of an emitter coupled differential signal amplifier (Q3, Q4). Base drive for transistor Q4 is a representative portion of the sensing voltage. Transistor Q3 is the reference side of the differential signal amplifier. It is controlled by the zener voltage of zener diode Z1.

The difference between the input signal to Q4 and the input signal to Q3 constitutes the error signal. The amplified outputs of Q3 and Q4 are applied to a amplifier stage Q1, Q2. Transistors Q1, Q2 in effect convert the voltage signal from

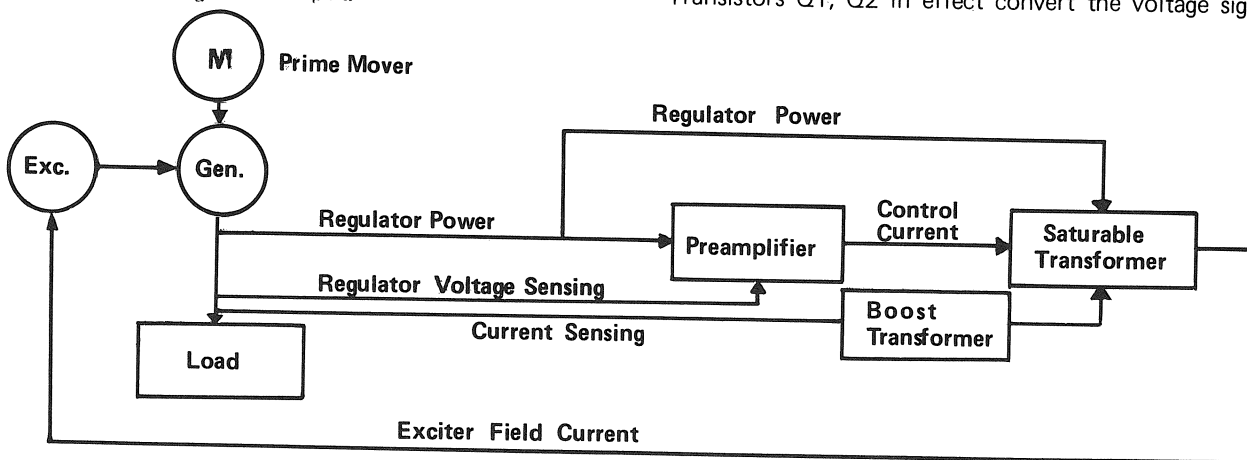

Figure 1 Closed Loop Control Diagram, Generator and Voltage Regulator System

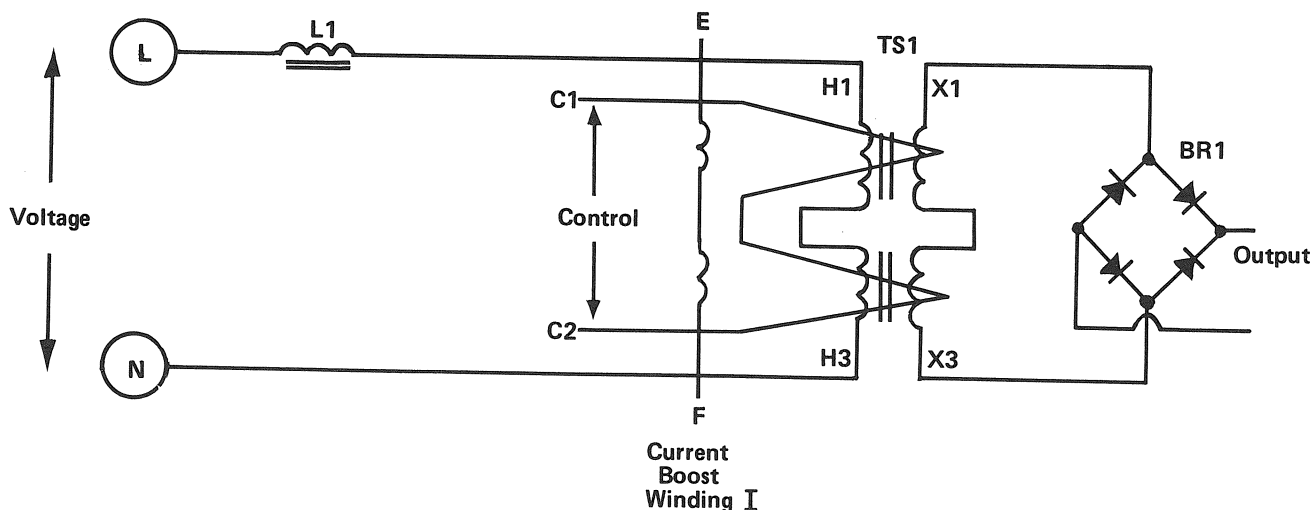

Figure 2 Magnetic Amplifier

the error detector to a ground level current signal. The current signal is applied to the control winding on saturable transformer TS1. Diodes D1 through D4 provide power for transistors Q1, Q2.

Capacitors C3, C4, resistors R15, R16 and Stability Adjust potentiometer R8 form a negative feedback system loop

stability circuit. The circuit injects a stabilizing signal from the regulator output into the error detector Q3 to prevent oscillations (hunting). Adjustment of potentiometer R8 determines the amount of stability signal applied to the error detector. Turning R8 clockwise improves stability. Turning it counter clockwise results in faster response. Optimum setting results when R8 is set so that generator voltage is stable at both no-load and with load applied and response is satisfactory.

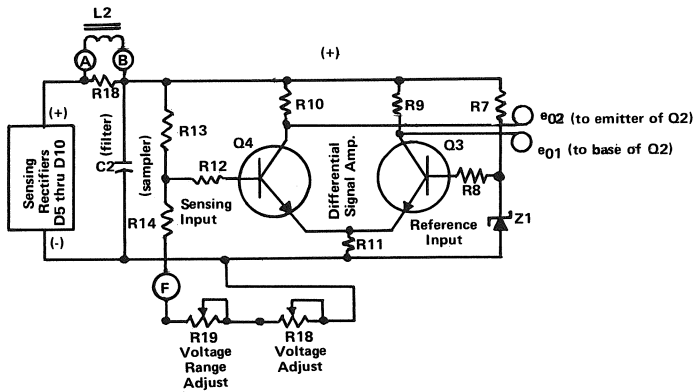

Figure 3 Error Detector

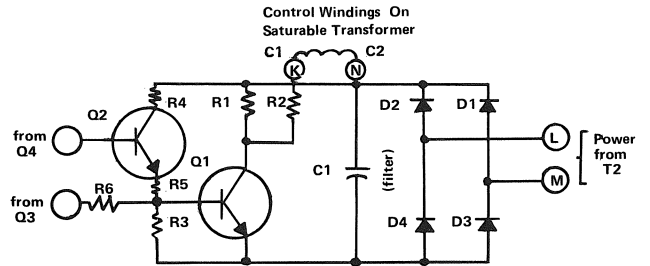
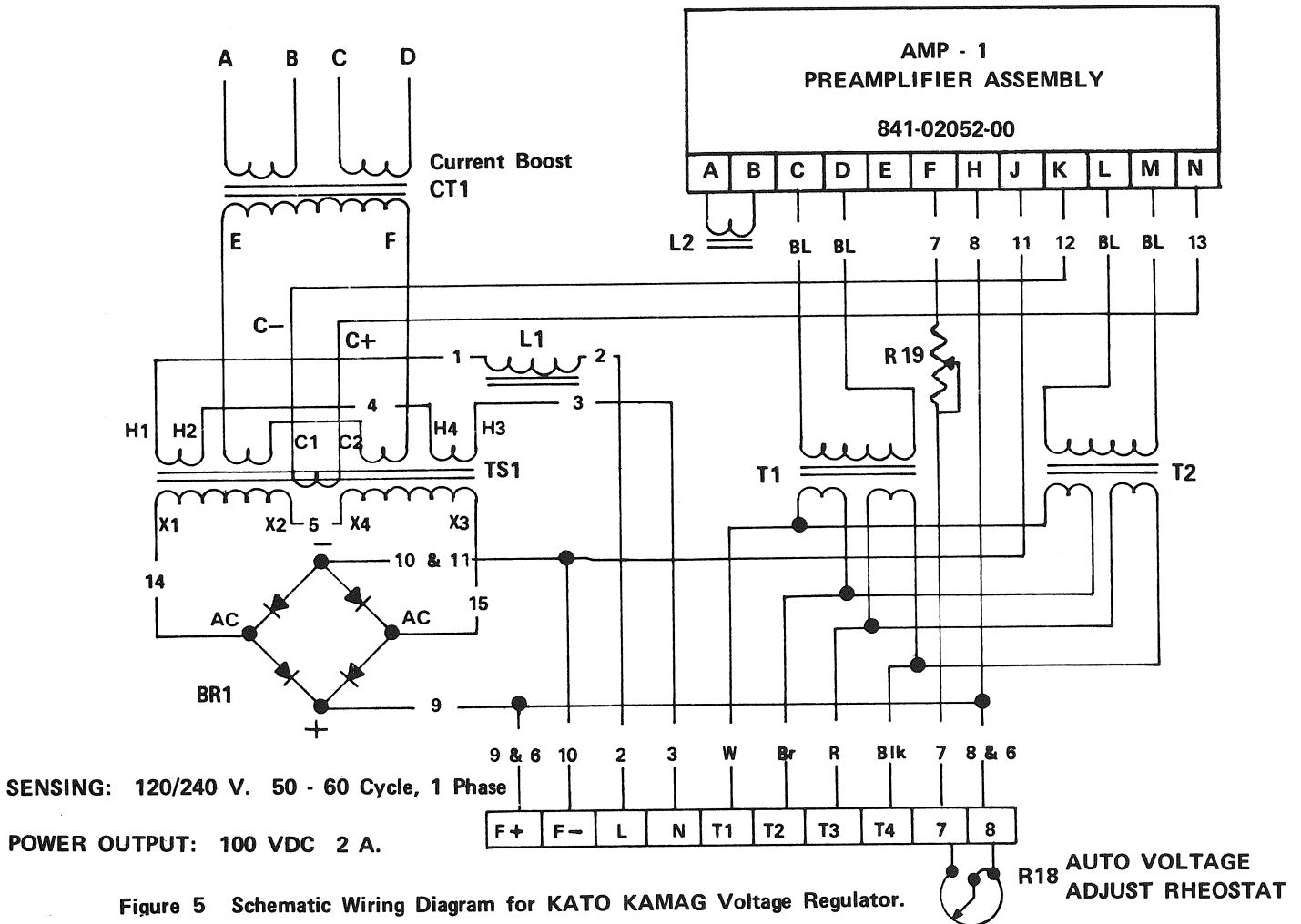

Figure 4 Amplifier Q1, Q2



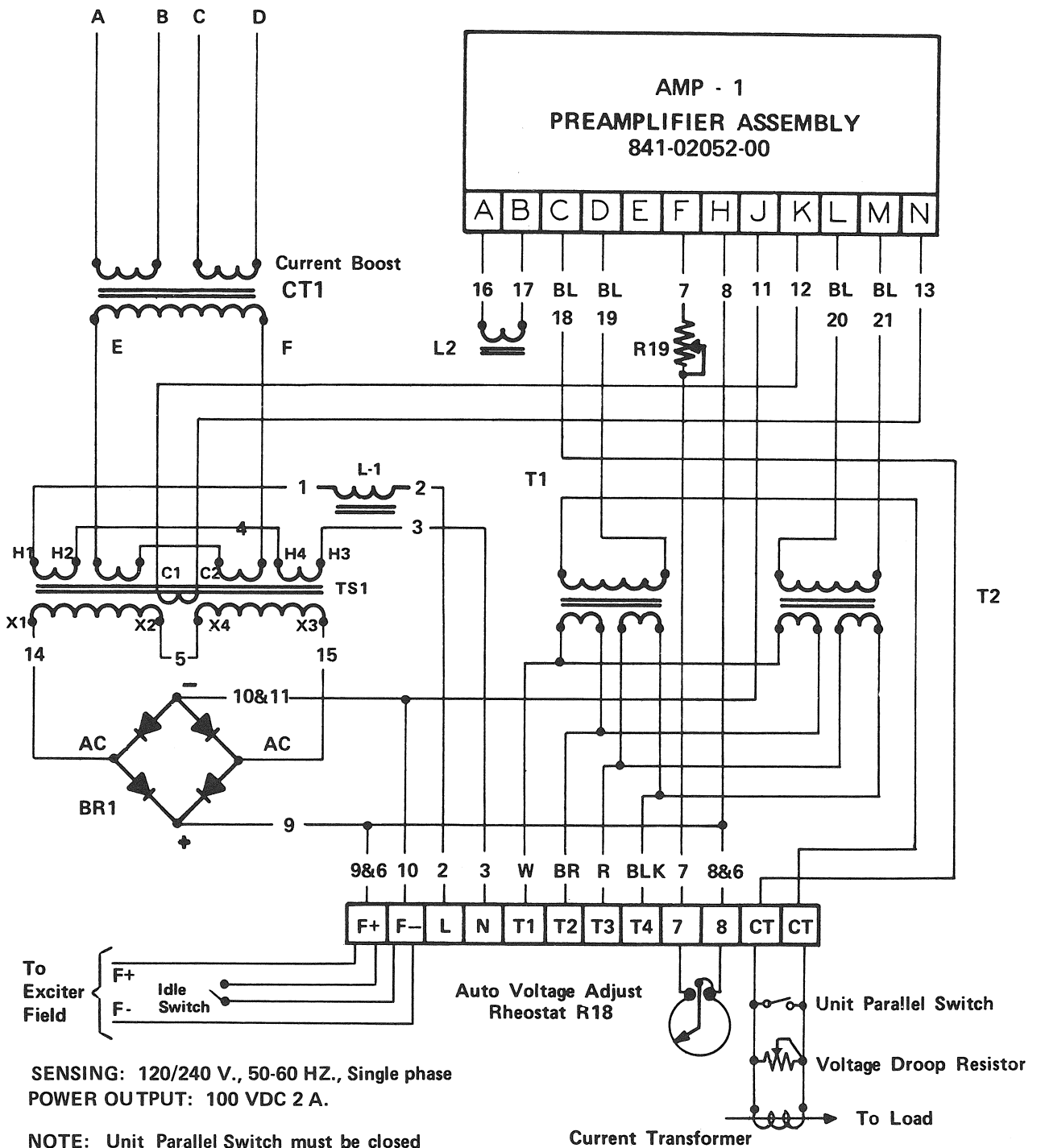
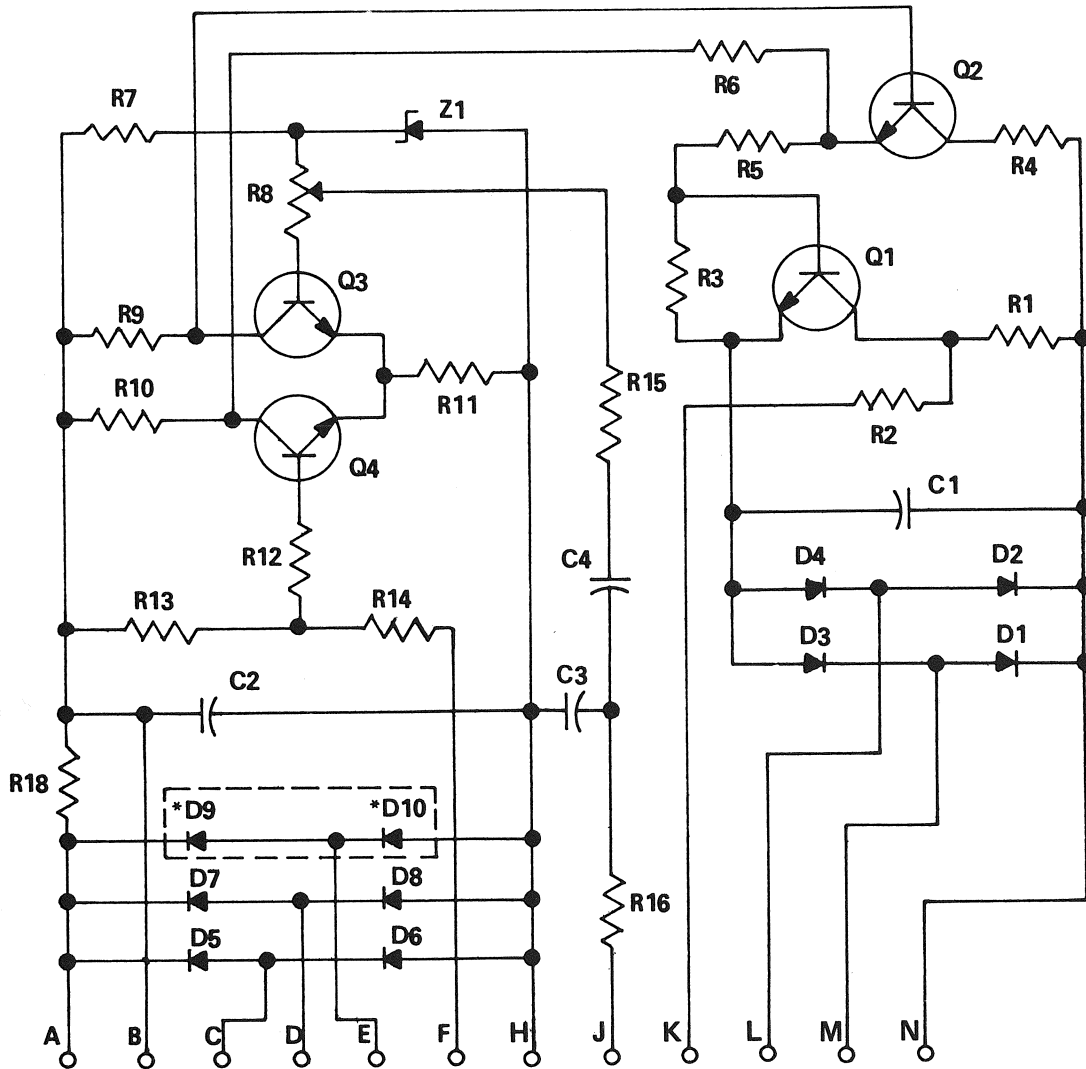

Figure 6 Electrical Schematic, KATO KAMAG Voltage Regulator with optional Paralleling Accessories and Optional Idle Switch.



* NOTE: D9 and D10 used only with 3 Phase Sensing

Figure 7 Schematic Wiring Diagram for KAMAG printed Circuit Board Voltage Regulator Preamplifier 841-02052-00.

SECTION 2 INSTALLATION & OPERATION

INSTALLATION

The KAMAG voltage regulator installed in the generator terminal box is completely interwired. Upon receipt of the generator, remove the terminal box cover and inspect terminal connections to make certain they are tight. Tighten any loose connections. Inspect lead wires for frayed or damaged insulation.

NOTE: Kamag voltage regulators are designed for use with broad range multiple voltage Kamag 14 and 18 generators. It has been connected at factory for generator voltage marked on generator set wiring diagram. In applications where generator is reconnected to provide a different voltage than factory hookup, leads to regulator terminal board and boost transformer must also be reconnected. Refer to appropriate connection diagram contained in generator manual. Contact KATO Engineering Company, Engineering Department, Mankato, Minnesota if additional information is needed. When requesting information, always include the generator serial and type numbers.

VOLTAGE ADJUSTMENT

Generator output voltage can be adjusted by turning the VOLTAGE ADJUST POTENTIOMETER R18 and VOLTAGE RANGE ADJUST POTENTIOMETER R19.

Initial operation should be made with the VOLTAGE ADJUST POTENTIOMETER R18 set to its mid-range position. When unit is at rated speed, turn R18 until desired output voltage is indicated on voltmeter.

If desired output voltage cannot be obtained by turning VOLTAGE ADJUST R18, turn VOLTAGE RANGE ADJUST R19.

Turning potentiometers clockwise increases voltage and when they are turned counter-clockwise, voltage will decrease.

When potentiometer shaft locknuts are incorporated, loosen locknut before turning potentiometer. Tighten locknut when voltage adjustment is complete.

STABILITY ADJUST R8

STABILITY ADJUST resistor R8 is located on the printed circuit board. Only adjust STABILITY ADJUST R8 if during operation oscillations (hunting) or poor response occurs. Turning STABILITY ADJUST clockwise injects a stabilizing signal into the error detector. Excessive clockwise rotation can, however, cause slow response. STABILITY ADJUST should be set so that the output voltage of the generator is stable at both no-load and full-load and response is satisfactory.

NOTE

Make certain unit is at rated speed when making voltage and stability adjustments (50 or 60 CPS whichever is being used).

ENGINE IDLE SWITCH

An idle switch may be installed on engine driven generators to permit engine warm-up at idle speed without inadvertent damage to the generator or devices that may be operated from the generator.

Close switch when operating unit below rated speed, open switch when unit is at rated speed. Switch should be open before applying load. Refer to figure 6, page 4 for recommended connection of idle switch in regulator circuit.

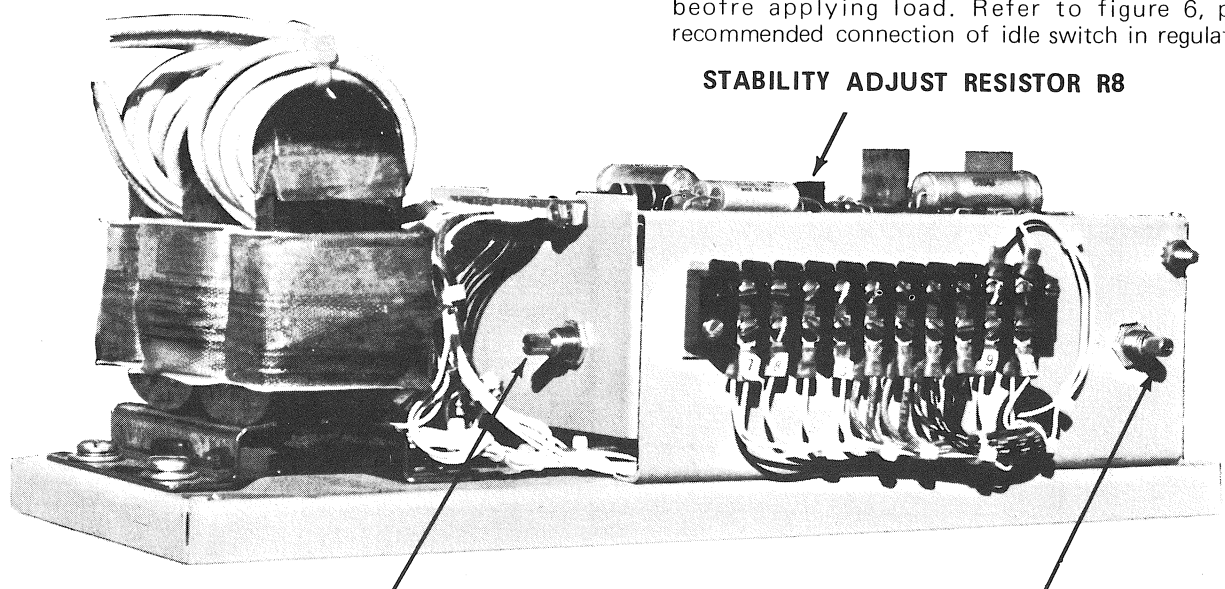

VOLTAGE RANGE ADJUST RHEOSTAT R19

VOLTAGE ADJUST RHEOSTAT R18

(NOTE: R18 supplied loose for remote mounting when requested)

Figure 8 Side View, Voltage Regulator.

SECTION 3 TROUBLESHOOTING

TROUBLESHOOTING CHART

SYMPTOM	PROBABLE CAUSE	PROBABLE REMEDY
No generator output voltage.	<p>No residual magnetism in exciter field.</p> <p>Shorted or open exciter armature, generator field or generator armature windings.</p> <p>Engine idle switch, when used, closed.</p> <p>Exciter rectifiers open.</p>	<p>Disconnect F+, F- leads at regulator and flash field with about 12 VDC.</p> <p>Measure resistance of windings as check for open windings. Check resistance to ground as check for shorted windings. If windings are open or shorted, return defective part to factory or authorized local repair shop.</p> <p>Open switch when unit is at rated speed.</p> <p>Test. Replace defective rectifiers.</p>
Generator output voltage low.	Voltage Adjust R18 and Voltage Range Adjust R19 not properly adjusted.	Adjust potentiometers. Refer to procedures outlined in Section 2.
Generator output voltage low but controllable at no load.	<p>Regulator or generator not connected correctly.</p> <p>Prime mover underspeed.</p> <p>Defective voltage regulator.</p>	<p>Connect as shown on generator set wiring diagrams.</p> <p>Increase speed to generator rated.</p> <p>Check sensing, error detector and amplifier circuits.</p>
Generator output voltage low at no load. No voltage control and exciter residual of about 25% of nominal.	Exciter field defective or regulator misconnected or defective.	Check connections to voltage regulator. Refer to generator set wiring diagrams. If connections are correct disconnect F+, F- leads at regulator and flash field with 12VDC. If voltage rises to near normal, regulator is probably defective and should be repaired or replaced. If voltage does not rise when field is flashed check exciter field resistance. Repair defective exciter field.
Generator output voltage low (50 - 90% rated at no load) and no regulator control.	<p>Low prime mover speed.</p> <p>Generator or regulator not connected correctly.</p> <p>Defective regulator</p> <p>Open voltage adjust or voltage range adjust potentiometer.</p>	<p>Check prime mover speed. Increase to rated value of generator.</p> <p>Check connections. Refer to wiring diagrams</p> <p>Separately excite with 12VDC connected to exciter field leads F+, F-. If voltage rises regulator is probably defective. Test regulator components. Repair or replace regulator.</p> <p>Test. Replace if defective.</p>
Generator output voltage high but controllable at no load.	<p>Prime mover speed high.</p> <p>Open sensing or shorted voltage adjust or voltage range adjust potentiometers.</p> <p>Defective error detector or amplifier.</p>	<p>Reduce speed to rated speed of generator.</p> <p>Check sensing circuit for poor connections. Check sensing transformer for open or shorted windings. Check voltage adjust potentiometers. Replace defective components.</p> <p>Test components located on printed circuit board.</p>

SYMPTOM	PROBABLE CAUSE	PROBABLE REMEDY
Generator output voltage normal at no load but increases under load.	Incorrect number of turns on Current Boost Transformers.	Check part number on regulator and current boost transformer.
Poor regulation. Generator output voltage normal at no load but collapses or drops under load. Load removal results in nominal voltage.	<p>Prime mover speed drops due to governor not functioning properly or excessive load for engine.</p> <p>Generator or regulator misconnected.</p> <p>Generator overloaded.</p> <p>Unbalanced load.</p> <p>Incorrect number of turns on Current Boost Transformer.</p> <p>Parallel drop components, adjusted or incorrectly connected (units with parallel droop components for parallel operation of generator).</p> <p>Regulator defective.</p> <p>Generator defective.</p>	<p>Adjust governor or if load is excessive for engine, reduce load.</p> <p>Check wiring diagrams. Reconnect if misconnected.</p> <p>Reduce to rated load.</p> <p>Balance load.</p> <p>Check part number on regulator and current boost transformer.</p> <p>Check adjustment of voltage droop resistor, a 4% droop is commonly used. Check connections. If polarity of circulating current transformer is wrong, reverse connections.</p> <p>Test by connecting separate excitation voltage to terminals F+, F-. About 30-60 VDC depending on KW load and power factor). If voltage is near normal voltage regulator is probably defective. Replace or repair.</p> <p>Test as described above. If near normal power does not result when unit is separately excited check generator connections and test winding resistance. Also test rotating rectifiers in exciter assembly.</p>
Poor response on load application.	<p>Same as "Poor Regulation".</p> <p>Regulator Stability Adjust requires adjustment.</p>	<p>Same as "Poor Regulation".</p> <p>Adjust as described in Section 2. Normally a regulator which is stable at no load will remain stable when steady state load is applied.</p>
Voltage fluctuates, oscillates or hunts.	<p>Prime mover speed fluctuating.</p> <p>Load too heavy for engine.</p> <p>Regulator Stability Adjust Resistor R8 requires adjustment.</p> <p>Variable load (transient load such as compressor).</p>	<p>Check. Repair defective governor.</p> <p>Reduce maximum load to within engine rating.</p> <p>Adjust as described in Section 2. Normally a regulator which is stable at no load will remain stable when steady state load is applied.</p> <p>If objectionable, contact factory stating load conditions.</p>

SECTION 4 PREVENTIVE MAINTENANCE

PERIODIC INSPECTION AND CLEANING

Inspect and clean the voltage regulator and control box approximately four times a year as follows:

- a. Shutdown generator. Then remove terminal box cover.

WARNING

Avoid exposure to dangerous voltage. Do not attempt to repair or clean parts within the terminal box when generator is running

- b. Inspect lead wires and terminal connections. Repair any frayed or worn lead wire insulation. Tighten any loose terminal connectors. Clean excessive dirt from lead wires with clean cloth.

- c. Clean dirt from voltage regulator and terminal box with vacuum cleaner or use filtered compressed air at a pressure of from 25 to 40 psi.
- d. Check regulator and terminal box for loose mounting bolts or nuts. Tighten any loose connections.
- e. Replace terminal box cover before starting generator.

ORDERING REPLACEMENT PARTS

Should a defect in the regulator occur, we recommend return of the complete regulator assembly to the KATO Factory for testing and repair. Always include the serial number and type number of the generator.

SECTION 5 COMPONENT TEST PROCEDURES

CAUTION

MEGGERs AND HIGH POTENTIAL TEST EQUIPMENT SHOULD NOT BE USED. INCORRECT USE OF SUCH EQUIPMENT COULD DESTROY THE RECTIFIERS, TRANSISTORS AND CAPACITORS IN THE REGULATOR.

WHEN TESTING OF INSULATION RESISTANCE OF GENERATOR WINDINGS WITH MEGGER, FIRST DISCONNECT LEADS BETWEEN REGULATOR AND GENERATOR.

NOTE

When testing components which are connected in circuits, care should be taken that other components in the circuit do not affect readings.

RECTIFIER TEST

A. General

Small brown surface marks, sometimes developed by rectifiers during normal operation, usually do not adversely affect rectifier operation.

B. Procedure

Test with ohmmeter or three-volt test light as follows:

- (1) Connect ohmmeter or test light leads across rectifier. observe ohmmeter reading, or if test light is used, observe if bulb lights.

- (2) Reverse leads. Again observe ohmmeter reading; or, if test light is used, observe if bulb lights.

- (3) A good rectifier will have high resistance in one direction and low resistance in the opposite direction. If a test lamp is used, the bulb should light in the direction where resistance is low, and should not light in the direction where resistance is high. If a low resistance is indicated in both steps 1) and 2), the rectifier is probably shorted. High resistance in both steps 1) and 2) indicates an open rectifier.

CAPACITOR TEST

- 1) Capacitors may be checked on a capacitor bridge to measure capacitance and leakage. Capacitance should not vary more than plus or minus 10% of their rated values.
- 2) An approximate check may be made with an ohmmeter set to a high-resistance scale. The meter should initially indicate low resistance and then gradually increase until capacitor is fully charged.

SATURABLE TRANSFORMER

Typical defects are open or shorted windings. Open windings can be determined by disconnecting the transformer from the circuit and then testing continuity of the windings. Shorted windings generally may be detected by checking resistance of the transformer windings with the winding resistance of an identical transformer known to be in good condition.

POWER TRANSFORMER TEST

- 1) With rated voltage on the primary winding, check the secondary voltages. Measured voltages, taken when a transformer is unloaded, run up to about 10% higher than those taken when the transformer is wired into its circuit.
- 2) Typical transformer defects are shorts between windings, open windings, and shorted turns. These usually may be detected by checking resistances and voltages. When the transformer overheats, and the existence of shorted turns cannot be proved by resistance measurement, check the no-load alternating current in the primary winding. This excitation current will be excessive if there are shorted turns.

CURRENT TRANSFORMER TEST

Current transformers have a fixed ratio of current between primary and secondary. The ratio between these currents is determined by the turns ratio. The following test should be made for shorted turns.

- 1) Load the generator to produce primary current in the transformer.
- 2) Measure the secondary current.

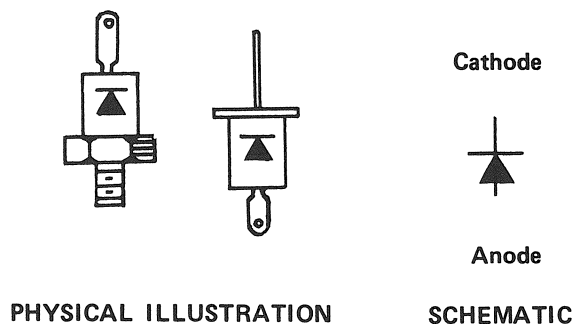

Figure 9 Silicon Rectifier

CAUTION

DO NOT OPEN THE SECONDARY OF A CURRENT TRANSFORMER WHILE THE CIRCUIT IS ENERGIZED.

The ratio of primary to secondary current is approximately the same as the ratio of secondary turns to primary turns. If secondary current is considerably less than it should be, shorted turns are indicated.

POTENTIOMETERS AND RESISTORS

Check resistance values with an ohmmeter. Potentiometers and adjustable resistors should be checked over their full range. Care should be taken to avoid damage to the fine wire when setting adjustment bands on adjustable resistors. The adjustment band should be loosened until it slides freely on the resistor tube.

SILICON TRANSISTOR TEST

Silicon transistors can be tested with a three-volt test light as detailed in the following chart. Test by test light method will normally indicate if a transistor is open or short circuited. Remove transistor from circuit to prevent other components in circuit from affecting readings. The light indications listed in the following table are those which should be observed if transistor is not shorted or open. Location of base, emitter and collector lead are shown in figure 11. See page 11 for Transistor Test Chart.

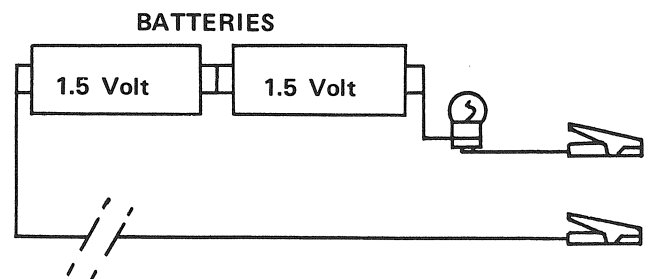

Figure 10 Three Volt Test Light

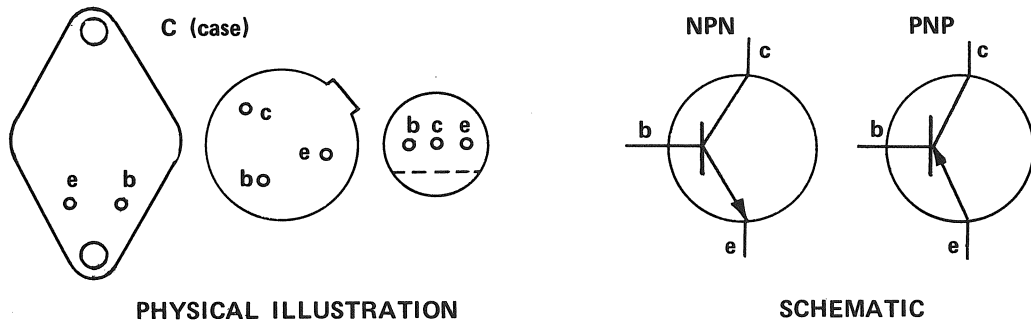

Figure 11 Silicon Transistors

TRANSISTOR TEST CHART

TYPE TRANSISTOR	TEST LAMP NEGATIVE LEAD CONNECTED TO-	TEST LAMP POSITIVE LEAD CONNECTED TO-	LIGHT INDICATION
NPN	BASE BASE	EMITTER COLLECTOR	NO LIGHT NO LIGHT
	EMITTER COLLECTOR	BASE BASE	LIGHT LIGHT
PNP	BASE BASE	EMITTER COLLECTOR	LIGHT LIGHT
	EMITTER COLLECTOR	BASE BASE	NO LIGHT NO LIGHT

ZENER DIODE TEST

A zener diode may be checked with an ohmmeter in much the same manner that a normal rectifier is checked or if a DC power supply is available a check on the actual operation of the zener may be performed. Utilizing the test setup illustrated in figure 12 the voltage across the diode will increase until it reaches the zener voltage. As the DC input voltage is increased the voltage across the diode will remain constant and the current through the diode will increase rapidly. Care should be taken not to exceed the current rating of the diode. The DC power supply should have a low ripple. A battery is preferred.

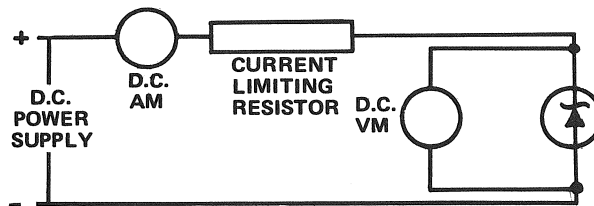

Figure 12 Zener Diode Test

REGULATOR VOLTAGE AND RESISTANCE MEASUREMENTS

Typical voltage and resistances across various circuits in the voltage regulator are outlined in the following table. The measurements were taken using a multimeter. Voltage measurements were taken with no load on generator and generator output voltage was adjusted so that 135 VAC appeared at regulator terminals L to N. To take resistance measurements disconnect wires to regulator terminals F+, F-, L, N, T1, T2, T3, and T4. Leave wires on terminals 7 and 8.

Point of Measurement	Typical Reading (approx. may vary slightly)
Printed circuit board terminals A to B	260 ohms
Printed circuit board terminals F to H	0-1500 ohms depending on setting of R18 & R19
Printed circuit board terminals C and D	30 VAC, 6.5 ohms
Printed circuit board terminals L to M	30 VAC, 6.5 ohms
Printed circuit board terminals K (C-) to N (C+)	3.5 VDC
Printed circuit board across Z1	Zener Voltage 8.2 VDC
Printed circuit board, junction of resistors R13, R14 to P.C. terminal H	8.2 VDC nominal, varies with changes in sensing and setting of R18, R19.
Regulator terminal board, terminals L to N	135 VAC
Regulator terminal board, terminals T1 to T2	120 VAC
Regulator terminal board, terminals T3 to T4	120 VAC
Regulator terminal board, terminals F+ to F-	13 VDC
Saturable transformer TS1, terminal H1 to H3	28 VAC, 6.5 ohms
Saturable transformer TS1, terminal H1 to regulator terminal L	107 VAC
Saturable transformer TS1, terminal X1 to X3	20 VAC, 6.5 ohms



Kato Engineering Support

The brand you trust, the power you depend on. Include the serial number and model number for your machine in the email subject line.

Field Service

KatoService@mail.nidec.com

Parts

KatoParts@mail.nidec.com

Remanufacturing

KatoRemanufacturing@mail.nidec.com

Warranty/Quality Assurance

KatoWarranty@mail.nidec.com